

SASO GSO IEC 60335-2-17

**HOUSEHOLD AND SIMILAR ELECTRICAL APPLIANCES–
SAFETY –**

**PART 2-17: PARTICULAR REQUIREMENTS FOR
BLANKETS, PADS, CLOTHING AND SIMILAR FLEXIBLE
HEATING APPLIANCES**

CONTENTS

FOREWORD	4
INTRODUCTION	5
1 Scope	6
2 Normative references	7
3 Definitions.....	8
4 General requirement	11
5 General conditions for the tests	11
6 Classification	13
7 Marking and instructions.....	13
8 Protection against access to live parts	17
9 Starting of motor-operated appliances	17
10 Power input and current	17
11 Heating	17
12 Void.....	20
13 Leakage current and electric strength at operating temperature	21
14 Transient overvoltages	22
15 Moisture resistance	22
16 Leakage current and electric strength	24
17 Overload protection of transformers and associated circuits	25
18 Endurance	25
19 Abnormal operation	25
20 Stability and mechanical hazards.....	31
21 Mechanical strength	31
22 Construction	42
23 Internal wiring	45
24 Components	45
25 Supply connection and external flexible cords	46
26 Terminals for external conductors	47
27 Provision for earthing	47
28 Screws and connections	47
29 Clearances, creepage distances and solid insulation	47
30 Resistance to heat and fire	48
31 Resistance to rusting.....	52
32 Radiation, toxicity and similar hazards	52

Annexes.....	65
Annex A (informative) Routine tests	65
Annex AA (normative) Specification for the thermal insulation.....	67
Annex BB (normative) Equipment for the mechanical strength test for blankets.....	69
Annex CC (normative) Clothing	73
Bibliography.....	77
Figure 101 – Symbol for "Do not use folded or rucked"	53
Figure 102 – Symbol for "Do not insert pins"	53
Figure 103 – Void.....	53
Figure 104 – Arrangement for measuring leakage current and electric strength of the flexible part.....	54
Figure 105 – Arrangement for the three-thickness fold test	55
Figure 106 – Examples showing the position of the thermal insulation on ruck-resistant blankets and mattresses.....	56
Figure 107 – Examples of folds and the position of the thermal insulation on pads.....	57
Figure 108 – Tumbling barrel for testing the mechanical strength of pads.....	58
Figure 109 – Impact apparatus for testing enclosures of moisture-proof appliances.....	59
Figure 110 – Shape of the sample for the tear resistance test	60
Figure 111 – Equipment for flexing heating elements and internal wiring	61
Figure 112 – Arrangement for the rigidity test of ruck-resistant blankets.....	62
Figure 113 – Equipment for the spark ignition test	63
Figure 113a – Details of the mask.....	64
Figure BB.1 – Equipment for the mechanical strength test of blankets.....	71
Figure BB.2 – Detail of the drum and cylinders	72
Figure BB.3 – Detail of the clamping bar	72
Table 101 – Maximum temperatures.....	19
Table 102 – Maximum temperature rises	19
Table A.101 – Test voltages	65
Annex AAA (normative) National Modifications for the Values of the Rated Voltages and Frequencies	78

FOREWORD

The Saudi Standards and Quality Organization (SASO) has adopted the international standard IEC 60335-2-17/2009Ed2.2 "Household and Similar Electrical Appliances - Safety - Part 2-17: Particular Requirements for Blankets, Pads, Clothing and Similar Flexible Heating Appliances" including its Amendments No. 1/2006 and No. 2/2008, issued by the International Electrotechnical Commission (IEC).

SASO has also translated this International Standard into Arabic without introducing any modifications.

Annex "AAA" given at the end of this Standard lists the National Modifications to be carried out on the Arabic and English texts of the above-mentioned Standard in order to suit the Electrical distribution System in the Kingdom.

Note: On implementing this Saudi Standard, the Saudi Standards corresponding to the International Standards, if any, mentioned in this adopted Saudi Standard shall be taken into consideration.

Introduction

The Saudi Arabian Standards Organization (SASO) has adopted the International Standard IEC 60335-1/2001 "Household and Similar Electrical Appliances– Safety - Part 1: General Requirements" including its Amendments No. 1/2004 and No. 2/2006, and approved as Saudi Standard SASO 1602/2007. SASO has also issued a number of standards each of which is concerned with the requirements of a particular electrical appliance and among which is IEC 60335-2-17/2009 "Household and Similar Electrical Appliances - Safety - Part 2-17: Particular Requirements for Blankets, Pads, Clothing and Similar Flexible Heating Appliances" including its Amendments No. 1/2006 and No. 2/2008.

In order to apply this Saudi Standard, it should be read in conjunction with SASO 1602/2007 because the Clause numbers herein are the same as those of Part 1. If a Clause in Part 1 is not applicable to this standard, the Clause number is included herein but with the words "Not applicable". And if a Clause in Part 1 has been replaced by new text to suit this standard, the Clause number herein is followed by the word "Replacement" and the new text of this Clause then follows on the next line. And if any addition has been added to this standard, the Clause number herein is followed by the word "Addition" and the new addition then follows on the next line. And if any modification has been done on a Clause of Part 1, the Clause number herein is followed by the word "Modification" and the modified text then follows on the next line. In case of introducing new Sub-clause, they should take the Clause number of Part 1 followed by the divisions 101, 102, ... etc. In case of introducing new Figures, they should take the numerals 101, 102, ... etc. In case of introducing new Annexes and/or Figures for the Annexes, they should take the numerals AA, BB, etc.

SASO reviews also the Saudi Standards adopted from the corresponding International Standards in order to know to which extent they are appropriate to the conditions of the Kingdom. When SASO assures that there is a necessity to carry out Deletion and/or Replacement and/or Addition and/or Modification, etc. on any Clause and/or Sub-clause of the adopted Standard, SASO will list these in an **Annex of the National Modifications** which will be added at the end of the relevant Standard

HOUSEHOLD AND SIMILAR ELECTRICAL APPLIANCES – SAFETY –

Part 2-17: Particular Requirements for Blankets, Pads Clothing and Similar Flexible Heating Appliances

1 Scope

This clause of Part 1 is replaced by the following.

This International Standard deals with the safety of electric **blankets, pads** and other flexible appliances that heat the bed or human body, for household and similar purposes, their **rated voltage** being not more than 250 V.

This standard also applies to **control units** supplied with the appliance.

Appliances not intended for normal household use but which nevertheless may be a source of danger to the public, such as appliances intended to be used in a beauty parlours or by persons in cold ambient temperatures, are within the scope of this standard.

Requirements and tests for clothing are given in Annex CC.

As far as is practicable, this standard deals with the common hazards presented by appliances that are encountered by all persons in and around the home. However, in general, it does not take into account

- persons (including children) whose
 - physical, sensory or mental capabilities; or
 - lack of experience and knowledge

prevents them from using the appliance safely without supervision or instruction;

- children playing with the appliance.

NOTE 101 Children are considered to be old enough to use an appliance without supervision when they have been adequately instructed by a parent or guardian and are deemed competent to use the appliance safely.

NOTE 102 Attention is drawn to the fact that

- for appliances intended to be used in vehicles or on board ships or aircraft, additional requirements may be necessary;
- in many countries, additional requirements are specified by the national health authorities, the national authorities responsible for the protection of labour and similar authorities.

NOTE 103 This standard does not apply to

- appliances intended to be used in locations where special conditions prevail, such as the presence of a corrosive or explosive atmosphere (dust, vapour or gas);
- rigid bed warmers, such as those of metal or ceramic material;
- water bed heaters (IEC 60335-2-66);
- heating appliances for breeding and rearing animals (IEC 60335-2-71);
- foot warmers and heating mats (IEC 60335-2-81);
- appliances specifically intended for use under medical supervision (IEC 60601-2-35).

2 Normative references

This clause of Part 1 is applicable except as follows.

Addition:

ISO 2439, Flexible cellular polymeric materials – Determination of hardness (indentation technique)

ISO 3758, Textiles – Care labelling code using symbols

3 Definitions

This clause of Part 1 is applicable except as follows.

3.1.9 Replacement:

normal operation

operation of the appliance under the following conditions

Blankets and **pads** are placed between sheets of thermal insulation.

Duvets are placed on a sheet of thermal insulation but not covered.

Mattresses are covered by a sheet of thermal insulation.

NOTE 101 The specification for the thermal insulation is given in Annex AA.

The **flexible part** is supported on a plywood base 20 mm thick and positioned not less than 300 mm above the floor. The size of the plywood base is such that the thermal insulation can be fully supported over its entire area. The size of the sheets of thermal insulation is such that the edges extend at least 100 mm beyond the outline of the **heated area**.

Control units held in the hand when they are actuated and cord switches are positioned to hang away from the plywood base. Other **control units** are placed on a supporting surface away from the plywood base.

3.8.4 Replacement

PTC heating element

heating element consisting of two conductors separated by conductive material that has a rapid non-linear increase in resistance when the temperature is raised through a particular range

3.101**flexible part**

all layers of material forming the permanent enclosure of the appliance together with the **heating element**, **thermostats** and all other current-carrying parts contained within it

NOTE The **flexible part** may be inside a **detachable cover**.

3.102**blanket**

appliance comprising a substantially flat **flexible part** that is intended to form part of the bedding, for heating the bed

3.103**underblanket**

blanket intended to be used under the occupant of the bed

3.104**ruck-resistant blanket**

underblanket that has sufficient rigidity to prevent rucking of the **flexible part**

3.105**overblanket**

blanket intended to be used over the occupant of the bed

3.106**duvet**

quilted **overblanket** intended to be used without additional bedding over the occupant of the bed, the **heating element** providing supplementary heat

3.107**pad**

appliance comprising a **flexible part** having a **heated area** not exceeding 0,3 m² on each face and which is intended to heat part of the human body

3.108

Mattress

appliance for supporting the bedding and which incorporates an upholstered **flexible part** for heating the bed

3.109**controlled appliance**

appliance incorporating means in the **flexible part** for sensing changes in temperature when the appliance is operated under **normal operation**, thus automatically controlling the average power input

3.110**heating element**

heating conductor, including the core on which it is wound and the insulation, together with any other integrated conductor

3.111**heated area**

area of the **flexible part** enclosed within the outer perimeter of the **heating element** or **electro-conductive textile**. It includes a margin outside the perimeter that has a width equal to 0,5 times the average distance between adjacent runs of the **heating element**.

NOTE 1 The **heated area** includes the return length of the **heating element** if the average distance between this part and the adjacent **heating element** does not exceed the average distance between adjacent runs of the **heating element**.

NOTE 2 If a **blanket** or **mattress** has two separate **heated areas**, the surface between the two areas is considered to be part of the **heated areas**, if at any place the distance between the two **heating elements** does not exceed 1,5 times the average distance between adjacent runs of the **heating element**.

3.112**moisture-proof appliance**

appliance having a **flexible part** that is suitable for use under moist conditions

3.113**bonded enclosure**

enclosure of the **flexible part** that has the opposite faces joined together by means of an adhesive or by welding

NOTE The bonded enclosure may include several bonded layers of material.

3.114**control unit**

device, external to the **flexible part**, by means of which the average power input of the appliance can be adjusted or regulated.

NOTE 1 **Control units** may be incorporated in the **supply cord** or at the end of an **interconnection cord**.

NOTE 2 Multi-position cord switches are not considered to be **control units** unless they incorporate components for regulating the power input.

3.115**wrap**

appliance comprising a **flexible part** intended to be draped over the human body in order to keep it warm

3.116**electro-conductive textile**

textile incorporating carbon or other conductive material for the purpose of providing a uniformly heated surface

4 General requirement

This clause of Part 1 is applicable.

5 General conditions for the tests

This clause of Part 1 is applicable except as follows.

5.2 Modification:

The tests are carried out on two appliances, identified as appliance A and appliance B.

Addition:

For appliances having a **bonded enclosure**, additional appliances are required for the tests of 21.108 and 21.111. For other appliances, a length of 15 m of **heating element** is required for the tests of 21.111.

For **moisture-proof pads** subjected to the tests of 21.110, five additional appliances and 1 m² of enclosure material are required.

If heat-shrink material is used to insulate connections in the **flexible part**, a sample at least 150 mm in length is required for the test of 30.102.

NOTE 101 An additional appliance may be required for the test of 19.112.

NOTE 102 If a further appliance is required in order to continue testing after a test of Clause 19, it has to be adequately preconditioned taking into account 21.102 to 21.107.

NOTE 103 Additional samples of **pads** may be required for the test of 30.101.

5.3 Replacement:

The order in which the tests are carried out is as follows:

Appliance A: 7, 22.11, 8, 22.112, 10, 21.102 to 21.107, 22.108, 13, 15, 16, 17, 20, 25.15, 25.16, 19 (except 19.111), 21.108, 22.18, 30, 31 and 32.

Appliance B: 10, 11, 19.111, 21 (remainder), 22 (remainder), 23, 24, 25 (remainder), 26, 27, 28, 29 and 14.

NOTE 101 **Duvets** are tested as **overblankets**.

The **flexible part** of washable appliances is laundered twice in accordance with the instructions before testing is started.

If it is evident from the construction of the appliance that a particular test is not applicable, the test is not carried out.

5.5 Addition:

If the **flexible part** of the appliance is provided with a **detachable cover**, the tests are carried out with or without this cover, whichever is more unfavourable. However, **duvets** are tested without a **detachable cover**.

If the **heating element** can move in the channels, it is manipulated so that the individual runs are placed in the most unfavourable position.

5.6 Addition:

When testing appliances for d.c. only, the possible influence of polarity on the operation of the appliance is taken into account.

5.7 Modification:

For **flexible parts** incorporating **PTC heating elements**, the tests of Clauses 10, 11 and 19 are carried out at the most unfavourable ambient temperature within the range of 0 °C to 25 °C.

For other **controlled blankets** and **mattresses**, the tests of Clauses 10, 11 and 19 are carried out at the most unfavourable ambient temperature within the range of 0 °C to 15 °C.

5.8.1 Addition:

Appliances for d.c. only are tested with d.c.

5.8.2 Addition:

Controlled appliances are supplied as specified for **motor-operated appliances**.

NOTE Appliances incorporating **PTC heating elements** within the **flexible part** are considered to be **controlled appliances**.

5.101 Wraps are tested as **overblankets**.

6 Classification

This clause of Part 1 is applicable except as follows.

6.1 Modification:

Appliances shall be **class II** or **class III**. **Class III appliances** shall have a **rated voltage** not exceeding 24 V.

7 Marking and instructions

This clause of Part 1 is applicable except as follows.

7.1 Modification:

Appliances shall be marked with the **rated power input**.

Parts of **class III construction** shall not be marked with the **rated voltage** of the appliance.

Addition:

Flexible parts and **detachable covers** shall be marked with the name, trademark or identification mark of the manufacturer or responsible vendor.

Detachable covers shall be marked with the model or type reference of the appliance with which they are intended to be used.

The **flexible part** of appliances to be used with a **detachable control unit** shall be marked with the reference of the **control unit** to be used.

The **flexible part** of appliances to be used with a **detachable transformer** shall be marked with the reference of the transformer to be used.

Flexible parts and **detachable covers** shall be marked with the substance of the following:

- read the instructions or symbol 1641 of ISO 7000;
- do not use folded or rucked, or by the symbol of Figure 101 (only for **underblankets** other than those with **PTC heating elements**);
- do not insert pins or by the symbol shown in Figure 102;
- underblanket or overblanket, as appropriate;
- do not use if wet (this marking is not required for **moisture-proof appliances**);
- do not use with a helpless person, an infant or a person insensitive to heat;

The **flexible part** of **blankets** and **detachable covers** shall be marked with the appropriate laundering symbols specified in ISO 3758.

7.12 Addition:

The instructions shall contain the substance of the following:

Important instructions. Retain for future use.

The instructions shall contain the substance of the instructions required in 7.1. If symbols are used, they shall be explained.

The instructions for **underblankets**, other than **blankets** having a ruck-resistance greater than 1,2 as determined in 22.106, shall state how the **blanket** is to be secured to the bed.

The instructions shall specify the appropriate settings of controls for continuous use of the appliance.

The instructions for **pads** shall state that when the appliance is likely to be used for an extended period, for instance by the user falling asleep, controls should be adjusted to a setting recommended for continuous use.

The instructions for appliances provided with **detachable control units** or **detachable transformers** shall state that the appliance is only to be used with the types that are marked on the appliance.

The instructions for **duvets** shall state the length and width of the **detachable cover** to be used.

The instructions for appliances containing a fuse link or **thermal link** shall state that the appliance must be returned to the manufacturer or his agent if the link has ruptured.

The instructions shall state the substance of the following:

- when not in use, store as follows (quote necessary instructions);
- when storing the appliance, allow it to cool down before folding;
- do not crease the appliance by placing items on top of it during storage (for **blankets** and **pads** only);
- examine the appliance frequently for signs of wear or damage. If there are such signs or if the appliance has been misused, return it to the supplier prior to any further use;
- this appliance is not intended for medical use in hospitals.

The instructions for **underblankets** shall state the substance of the following:

- the appliance should not be used on an adjustable bed; or
- if the appliance is used on an adjustable bed, check that the blanket and cord do not become trapped or rucked, for example in hinges.

The instructions shall state that the appliance is not to be used by young children unless the controls have been pre-set by a parent or guardian, or unless the child has been adequately instructed on how to operate the controls safely.

7.14 Modification:

Instead of petroleum spirit, liquid detergent is used to check the marking on **flexible parts** and **detachable covers**.

Addition:

The height of the lettering on the **flexible part** shall be at least 2,5 mm.

The height of the symbols shown in Figure 101 and Figure 102 shall be at least 15 mm.

The height of the words "Important instructions" and "Retain for future use" shall be at least 6 mm.

Compliance is checked by measurement.

7.101 Detachable control units shall be marked with a reference number or by other means of identification.

Compliance is checked by inspection.

8 Protection against access to live parts

This clause of Part 1 is applicable.

9 Starting of motor-operated appliances

This clause of Part 1 is not applicable.

10 Power input and current

This clause of Part 1 is applicable except as follows.

10.1 Modification:

The negative deviation in Table 1 is increased to 20 %.

10.101 The power input of appliances incorporating **PTC heating elements** shall significantly decrease with an increase in temperature.

Compliance is checked by the following test.

The appliance is supplied at **rated voltage** and operated under **normal operation**. The power input shall have decreased by at least 50 % from the initial value when steady conditions are established, any control operating during this period being short-circuited.

11 Heating

This clause of Part 1 is applicable except as follows.

11.2 Modification:

The plywood base is placed away from the walls of the test corner.

Addition:

Duvets, other than those with **PTC heating elements**, are also tested folded. A single fold across the complete width of the **duvet** is made at a quarter of the length from one end. Controls are adjusted to the highest setting intended for continuous use.

Wraps are also tested folded. A single fold is made across the **flexible part** in the most unfavourable place.

11.3 Addition:

Thermocouples used for determining the temperature of **heating elements**, or sheaths containing them, are attached with textile thread over a length of at least 10 mm.

Thermocouples used for determining the temperature of the surface of **electro-conductive textiles** are attached to the centre of brass or copper plates measuring 65 mm x 65 mm x 0,5 mm. The plates are coated with insulating lacquer.

Thermocouples used for determining the temperature of the surface of **pads** are attached to plates of copper or brass measuring 65 mm × 65 mm × 0,5 mm. The plates are positioned to cover as many **heating element** runs as possible, with one side parallel to the direction of the run. The temperatures are determined at not less than six places, three on each outer surface of the **flexible part**.

11.4 Addition:

Controlled appliances and appliances having a **flexible part** of **class III construction** are supplied with the most unfavourable voltage between 0,94 and 1,06 times **rated voltage**.

11.7 Replacement:

Appliances are operated until steady conditions are established.

11.8 Addition:

For **controlled appliances**, the temperatures shall not exceed the values shown in Table 101. If the **flexible part** is comprised of **electro-conductive textile**, the values specified for **heating elements** are applicable to the surface of the material.

Table 101 – Maximum temperatures

Part	Temperature °C
Heating element of blankets and mattresses	
– before the second operation of the thermal control	115
– under steady conditions	95
Heating element of pads	
– before the second operation of the thermal control	120 ^a
– under steady conditions	100
Surface of pads	50 ^b
^a A temperature of 140 °C is allowed for a period of 10 min. ^b The temperature may exceed 50 °C, but not 85 °C, for a maximum period of 2 h. The period commences when the temperature first exceeds 50 °C.	

SAUDI ARABIAN STANDARD	SASO GSO IEC 60335-2-17/2008
-------------------------------	-------------------------------------

For other appliances, the temperature rises shall not exceed the values shown in Table 102.

Table 102 – Maximum temperature rises

Part	Temperature rise K^a
Heating element	80
Surface of pads	35
^a These values are based on the normal ambient temperature of the appliance and take into consideration the maximum allowed ambient temperatures during the test.	

NOTE 101 If the ends of the **heating element** of **pads** are contained in a plastic sheath attached to the **flexible part**, the temperature or temperature rise specified for the surface also applies to the **accessible surface** of the sheath.

11.101 It shall be possible to operate **blankets** and **mattresses** without risk of heatstroke to the user.

Compliance is checked by the following test.

The appliance is supplied as specified in 11.4 and operated under **normal operation** until steady conditions are established. The ambient temperature is maintained at the most unfavourable temperature between 0 °C and 15 °C. **Control units** and cord switches are adjusted to the highest setting recommended for continuous use, except for **wraps** when the lowest setting is used.

The temperature of the surface of the **flexible part** is determined by means of a thermocouple attached to the centre of a plate of copper or brass having dimensions 300 mm x 300 mm x 0,5 mm. For **overblankets**, the plate is placed under the **flexible part**. For **underblankets** and **mattresses**, the plate is placed over the **flexible part**.

The temperature shall not exceed 60 °C during the first hour of operation and thereafter shall not exceed 37 °C.

NOTE If the ends of the **heating element** are contained in a plastic sheath attached to the **flexible part**, the temperature limit specified also applies to the **accessible surface** of the sheath.

11.102 The surface temperature of **pads** shall not be excessive if they are used partially covered for an extended period.

Compliance is checked by the following test.

Pads are supplied as specified in 11.4 and operated under **normal operation** except that 2/3 of the **flexible part** is positioned so that it overhangs the edge of the plywood support. Controls are adjusted to their highest setting recommended for continuous use and the surface temperature of the pad is measured as specified in 11.3.

The temperature of the surface of the **flexible part** of **controlled pads** shall not exceed 85 °C and the temperature rise of the surface of other **pads** shall not exceed 60 K.

NOTE The covered portion may be secured to prevent the **pad** slipping off the support.

12 Void

13 Leakage current and electric strength at operating temperature

This clause of Part 1 is applicable except as follows.

13.1 Modification:

Controlled appliances are supplied at 1,06 times the **rated voltage**.

The tests are not applicable to **class III appliances** and **class III constructions**.

Addition:

For **mattresses**, a sheet of metal foil, approximately 0,1 mm thick and of sufficient size to cover the area of that part of the **mattress** incorporating the current-carrying parts, is inserted between the **mattress** and the sheet of thermal insulation. For other appliances, two such sheets of metal foil are inserted, one above and one below the **flexible part**, these sheets being electrically connected together. A uniformly distributed load of approximately 35 kg/m² is placed on the top sheet of thermal insulation.

The arrangement is shown in Figure 104.

13.2 Modification:

For the **flexible part**, the leakage current is measured between any pole of the supply and the sheets of metal foil.

Instead of the values specified, the leakage current for the **flexible part** shall not exceed

- for **pads**, 0,5 mA;
- for **blankets** and **mattresses**, 1 mA/m² of the **heated area**, with a maximum of 2,5 mA.

13.3 Modification:

For the **flexible part**, the test voltage is applied between **live parts** and the sheets of metal foil.

14 Transient overvoltages

This clause of Part 1 is applicable.

15 Moisture resistance

This clause of Part 1 is applicable except as follows.

15.1 Addition:

For the **flexible part**, compliance is checked as follows:

- for **blankets** and **pads**, by the test of 15.101;
- for **moisture-proof appliances**, by the tests of 15.101 and 15.102. However **pads** subjected to the tests of 21.109 and 21.110 are not subjected to the tests of 15.102;
- for **mattresses**, by the tests of 15.103.

The tests are not applicable to **class III appliances** and **class III constructions**.

NOTE 101 The tests of Clause 16 are carried out with the appliance still immersed or in contact with the saline solution.

15.3 Addition:

The **flexible part** is not subjected to the test.

15.101 Washable appliances are laundered according to the instructions.

The **flexible part** is then immersed for 1 h in water containing approximately 1 % NaCl at a temperature of $20\text{ °C} \pm 5\text{ °C}$ after removing **detachable parts**. All of the **flexible part** is immersed except

- appliance inlets;
- the point of entry of the flexible cord, unless it is a **moisture-proof appliance**;

- the connections of the **heating element** or internal wiring to the appliance inlet.

NOTE 1 All parts of the **flexible part** are immersed during laundering.

The appliance shall then withstand the electric strength test of 16.3 and inspection shall show that there is no trace of water on insulation that could result in a reduction of **clearances** and **creepage distances** below the values specified in Clause 29.

For **moisture-proof appliances**, inspection shall show that water has not penetrated the **flexible part** to such an extent that it could come into contact with **heating elements** and other current-carrying parts.

15.102 An incision is made in the permanent enclosure and the **flexible part** is then immersed in the saline solution that is allowed to penetrate freely into the interior.

After a period of 1 h, the appliance shall withstand the electric strength test of 16.3 and inspection shall show that there is no trace of water on insulation that could result in a reduction of **clearances** and **creepage distances** below the values specified in Clause 29.

15.103 Mattresses are supported on a piece of plywood. A quantity of water, containing approximately 1 % NaCl, corresponding to 1 l/m² of the upper surface area, is poured uniformly over the **mattress** at the rate of 1 l/min.

The saline solution is allowed to soak into the **mattress** for a period of 30 min.

The **flexible part** shall then withstand the electric strength test of 16.3 and inspection shall show that there is no trace of water on insulation that could result in a reduction of **clearances** and **creepage distances** below the values specified in Clause 29.

16 Leakage current and electric strength

This clause of Part 1 is applicable except as follows.

16.1 Addition:

The tests are not applicable to **class III appliances** and **class III constructions**.

16.2 Addition:

The **flexible part** of **blankets** and **pads** is tested with the voltage applied between **live parts** and an electrode immersed in the saline solution.

The **flexible part** of **mattresses** is covered with metal foil.

The leakage current of **flexible parts** shall not exceed

- for **pads**, 1 mA;
- for **blankets** and **mattresses**, 5 mA.

16.3 Modification:

The **flexible part** of **blankets** and **pads** is tested with the voltage applied between **live parts** and an electrode immersed in the saline solution. However, when the test is carried out on **blankets** and **pads** without first carrying out the tests of Clause 15, the **flexible part** is covered with metal foil instead.

Addition:

After the test, the **flexible part** of **blankets** and **pads** is thoroughly rinsed in water and then allowed to dry for at least 24 h at a temperature between 20 °C and 40 °C. During the drying period, the appliance is stretched in an attempt to regain the original dimensions.

Mattresses are rinsed with a quantity of water corresponding to 0,5 l/m² of the upper surface. The water is poured evenly over the upper surface and then

wiped with a sponge, soaking up as much water as possible. This treatment is carried out three times and the **mattress** is then wiped with a dry cloth.

17 Overload protection of transformers and associated circuits

This clause of Part 1 is applicable.

18 Endurance

This clause of Part 1 is not applicable.

19 Abnormal operation

This clause of Part 1 is applicable except as follows.

19.1 Modification:

Instead of the tests specified, the following applies.

Blankets, other than **ruck-resistant blankets**, are subjected to the tests of 19.101 to 19.103 and 19.108.

Ruck-resistant blankets are subjected to the tests of 19.104, 19.105 and 19.108.

Pads are subjected to the tests of 19.106, 19.108, 19.109 and 19.110.

Mattresses are subjected to the tests of 19.104 and 19.108.

Appliances incorporating a fuse-link or intentionally weak part that ruptures due to a short circuit are also subjected to the test of 19.107.

NOTE 101 Fuse-links that are incorporated in an appliance for compliance with 19.102 to 19.106 and 19.108 are not subjected to the tests of 19.12.

Appliances incorporating **electronic circuits** are also subjected to the tests of 19.11 and 19.12.

Unless otherwise specified, the appliance is supplied with a voltage

- between 0,9 times and 1,1 times the **rated voltage**, for **controlled appliances**,
- resulting in a power input between 0,85 times and 1,24 times the **rated power input**, for other appliances.

19.13 Addition:

NOTE 101 The test of 15.101 is carried out before the test of 16.3.

NOTE 102 It is considered that failure of an electronic switch in the **off position** or stand-by mode will not result in **dangerous malfunction** since the fault conditions of the appliance have been checked by the other tests of the standard, e.g. the different thickness fold tests of Clause 19.

The temperature of the **flexible part** in contact with the thermal insulation shall not exceed 165 °C for **controlled appliances** and the temperature rise shall not exceed 150 K for other appliances.

Unless the appliance is no longer in an operating condition after the tests, the temperature of **heating elements** shall not exceed 160 °C for **controlled appliances** and the temperature rise shall not exceed 145 K for other appliances.

19.101 Blankets, other than **ruck-resistant blankets**, incorporating **thermostats** or **thermal cut-outs** are operated under **normal operation** except that the **flexible part** is folded at the most unfavourable place with a three-thickness fold. The fold is 40 mm wide, 400 mm long and is fanned out at the ends, as shown in Figure 105. A sheet of thermal insulation, having dimensions of 300 mm × 450 mm × 36 mm, is placed on the folded **blanket** at the most unfavourable location.

For all **underblankets**, other than **ruck-resistant blankets**, the test is also carried out with the **flexible part** completely covered, as specified for **normal operation**.

19.102 Underblankets, other than **ruck-resistant blankets**, are operated under **normal operation** except that the **flexible part** is folded at the most unfavourable place with a five-thickness fold. The fold is 100 mm wide, 400 mm long and is fanned out at the ends. A sheet of thermal insulation, having dimensions of 300 mm × 450 mm × 90 mm, is placed on the folded **blanket** at the most unfavourable location. An evenly distributed mass of 5 kg is placed on the sheet of thermal insulation.

NOTE A sandbag may be used as the mass.

The appliance is supplied with a voltage at the upper limit of the range specified in 19.1.

19.103 Overblankets are operated under **normal operation** except that the **flexible part** is folded at the most unfavourable place with a five-thickness fold. The fold is of any equal width up to 75 mm, it is 400 mm long and is fanned out at the ends. A sheet of thermal insulation, having dimensions of 300 mm × 450 mm × 36 mm, is placed on the folded **blanket** at the most unfavourable location. An evenly distributed mass of 5 kg is placed on the upper sheet of thermal insulation.

NOTE A sandbag may be used as the mass.

The test is carried out with the **flexible part** uncovered, if this is more unfavourable.

19.104 Controlled ruck-resistant blankets and controlled mattresses are operated under **normal operation** except that the upper sheet of thermal insulation covers only one-third of the **flexible part**. The thermal insulation is applied in the most unfavourable position. Examples of positions are shown in Figure 106.

19.105 Ruck-resistant blankets are operated under **normal operation** except that the **flexible part** is folded at the most unfavourable place with a three-thickness fold having the most unfavourable dimensions. A sheet of thermal insulation, having dimensions of 300 mm × 450 mm × 90 mm, is placed on the folded **blanket** at the most unfavourable location. An evenly distributed mass of 5 kg is placed on the sheet of thermal insulation.

NOTE A sandbag may be used as the mass.

19.106 Pads are operated under **normal operation** except that the **flexible part** is folded with a double-thickness fold. The fold is parallel to one of the edges of the **flexible part**, the place and the width of the fold being selected to produce the most unfavourable result. The upper surface of the **flexible part** is uncovered or partially covered by a sheet of thermal insulation, whichever is more unfavourable. The thermal insulation has a length equal to the width of the pad and a width equal to one-third of the length of the pad. It is 36 mm thick and is placed in the most unfavourable position.

NOTE Examples of folds and the position of the thermal insulation are shown in Figure 107.

19.107 If compliance with 19.101 to 19.106 depends on the rupturing of a fuse-link or intentionally weak part, the test is repeated with the **flexible part** arranged as specified but with the point of maximum impedance of the protection circuit included in the most unfavourable part of the fold. The appliance is supplied with a voltage at the lower limit of the range specified in 19.1.

19.108 Appliances are operated under the conditions specified in Clause 11. Any control that limits the temperature during the test of Clause 11 is short-circuited.

NOTE If the appliance incorporates more than one control, they are short-circuited in turn.

19.109 Pads are operated under **normal operation** except that two-thirds of the **flexible part** is positioned so that it overhangs the edge of the plywood support.

NOTE The covered portion may be secured to prevent the pad slipping off the support.

19.110 Pads are operated under **normal operation** except that **the flexible part** is folded at the most unfavourable place with a three-thickness fold. The fold is up to 40 mm wide and of any length up to the width of the **pad**. The upper sheet of thermal insulation has dimensions of 300 mm x 450 mm x 36 mm and is placed on the folded **pad** at the most unfavourable location. An evenly distributed mass of 5 kg is placed on the upper sheet of thermal insulation.

NOTE A sandbag may be used as the mass.

[

19.111 Appliances shall be constructed so that failure of a component does not give rise to an excessive temperature.

Compliance is checked as follows.

Blankets and **mattresses** are operated under the conditions of 11.101.

Pads are operated under **normal operation**. Controls are adjusted to the highest setting recommended for continuous use, the **pad** being supplied as specified in 11.4.

Failure of components that could reasonably be expected to occur in normal use is simulated, except that switching contacts are not short-circuited. Only one fault condition is applied at a time.

NOTE 1 **Heating elements** and internal wiring are not considered to be components.

NOTE 2 Failure of components that could be expected are the fault conditions specified in a) to f) of 19.11.2.

During the test, the temperature of the surface of the **flexible part** shall not exceed

- 60 °C, for blankets and mattresses;
- 85 °C, for **controlled pads**. For other **pads**, the temperature rise shall not exceed 60 K.

19.112 Appliances incorporating **heating elements** or internal wiring having stranded conductors shall not attain excessive temperatures in normal use if one or more strands are broken.

Compliance is checked by the tests of 19.112.1 to 19.112.3 as appropriate or by assessment of the protection system.

NOTE Any unsheathed core of a flexible cord within the **flexible part** extending more than 100 mm from the cord anchorage is considered to be internal wiring.

19.112.1 If **heating elements** or internal wiring do not have integral insulation, and have individual strands that are not electrically insulated from each other, the enclosure of the **flexible part** is opened at the most unfavourable place and a short length of the bare conductor is exposed. All but one of the strands are cut and folded back by approximately 15 mm. The enclosure is then closed and the appliance operated under **normal operation** for 4 h.

If the single strand ruptures before any damage occurs, the test is repeated with the number of uncut strands increased to the minimum necessary to prevent rupturing.

After the test, there shall be no scorching of the enclosure or of any material in contact with the uncut strands.

19.112.2 If **heating elements** or internal wiring have integral insulation, and have individual strands that are not electrically insulated from each other, the enclosure of the **flexible part** is opened at the most unfavourable place and a short length of the insulated conductor is exposed. A single identical strand 100 mm long is wrapped for one complete turn around the insulation of the conductor, the ends of the turn being spaced 1 mm apart. The strand is connected in series with the conductor, the enclosure is then closed and the appliance operated under **normal operation** for 4 h.

If the single strand ruptures before any damage occurs, the test is repeated with the number of strands increased to the minimum necessary to prevent rupturing.

After the test, there shall be no damage to the insulation of the conductor or to other material of the **flexible part**.

NOTE A slight indentation of the insulation of the conductor is neglected.

19.112.3 If **heating elements** or internal wiring have individual strands that are electrically insulated from each other, the **heating element** or wiring is

disconnected from its terminals. A d.c. voltage of approximately 500 V is applied for 1 min between any two strands.

The insulation resistance is measured and shall not be less than

- for **class III appliances**, 0,1 M Ω ;
- for other appliances, 1 M Ω .

20 Stability and mechanical hazards

This clause of Part 1 is applicable except as follows.

20.1 Addition:

The test is only applied to **control units** intended to be placed on a surface.

21 Mechanical strength

This clause of Part 1 is applicable except as follows.

21.1 Addition:

Control units intended to be placed on a surface are also subjected to the test of 21.101.

Compliance for the **flexible part** is checked as follows:

- for **blankets**, by the tests of 21.102, 21.105 and 21.106;
- for **mattresses**, by the tests of 21.104 to 21.106;
- for **pads**, by the tests of 21.103 and 21.105 to 21.107.

After these tests, inspection of the **flexible part** shall not show

- damage between busbars and **electro-conductive material** or between busbars and their connections.
- damage to the enclosure or displacement of the **heating element** to such an extent that compliance with the standard is impaired;
- breakage of the conductors of the **heating element**;
- breakage of more than 10 % of the strands of internal wiring;
- failure of constructional stitching, or breakage of glued or welded joints, to such an extent that compliance with the standard is impaired;
- loosening of a **non-detachable flexible cord** from the **flexible part**;
- loosening or breakage of electrical connections;
- open-circuiting of controls incorporated in the **flexible part**.

NOTE 101 An example of damage to the enclosure that could impair compliance with the standard is cracking or tearing of the enclosure if it provides electrical insulation or protection against moisture. Compliance with the standard is also considered to be impaired if the **heating element** has moved in the channels so that two runs come into contact with each other.

21.2 Addition:

This subclause is not applicable to **flexible parts**.

21.101 The **control unit** is dropped from a height of 40 mm onto a rigidly mounted steel plate having a thickness of at least 15 mm and a mass of at least 15 kg. It is dropped so that it lands on its base, the test being carried out 100 times.

The **control unit** is then dropped three times from a height of 500 mm onto a hardwood floor by pulling it from a horizontal support by means of its cord so that it falls freely.

After the test, the **control unit** shall not be damaged to such an extent that compliance with this standard is impaired. If the **control unit** still operates, the appliance shall withstand the tests of Clause 11.

21.102 Blankets are securely attached to the apparatus described in Annex BB.

The **blanket** is pulled by the driving bar, the driving sprocket operating at a speed of 33 rev/min.

The **blanket** is rotated 1 000 times with an end attached to the driving bar. It is then turned through 90° and rotated another 1 000 times.

NOTE 1 The test is carried out with the same face of the **blanket** adjacent to the drum.

NOTE 2 When it is obvious which end of the **blanket** is intended to be positioned at the head of the bed, that end is attached to the driving bar. When this is not obvious, the end opposite the cord entry is attached to the driving bar.

NOTE 3 When the **blanket** is turned through 90°, the side opposite the cord entry is attached to the driving bar.

21.103 Pads, with any **detachable cover** removed, are driven backwards and forwards over a smooth horizontal roller having a diameter of 25 mm. The **pad** is arranged so that one end hangs vertically over the roller while the full length of the other end is clamped to the driving means, which moves in a horizontal plane.

A clamp is attached to the end of the vertical part of the **pad** over its full length. A mass of 0,5 kg, or equivalent to 3 g/mm of the length of the attached end, whichever is greater, is attached to the clamp.

The stroke of the driving means is such that the greatest possible area is subjected to flexing.

The driving means is operated at a rate of approximately 125 mm/s for 2 000 cycles. The **pad** is then turned through 90° and subjected to a further 2 000 cycles.

NOTE 1 The test is carried out with the same face of the **pad** adjacent to the roller.

NOTE 2 A cycle is two movements, one in each direction.

21.104 Mattresses are laid flat on a horizontal plywood support. A roller of similar construction to the drum specified in Annex BB, having a mass of 61,5 kg and a length of 1 m, is rolled slowly forwards and backwards over the upper surface of the **flexible part** in the most unfavourable place. The roller is applied in the direction of the major axis over the same path for 1 000 cycles.

NOTE A cycle is two movements, one in each direction.

21.105 Appliances are operated for 500 h continuously under the conditions specified in Clause 11. The surface temperature of the **flexible part** of **controlled appliances** is measured under steady conditions at the beginning and at the end of this period. It shall not have increased by more than 5 K. If the operation of the **protective device** is likely to be adversely affected by aging of the temperature-sensing system, the duration of the test is increased to 1 000 h.

For appliances with **PTC heating elements**, the test is carried out for 1 000 h but with the **flexible part** fully covered with a sheet of thermal insulation 90 mm thick. The temperature of the **PTC heating element** is measured after 100 h and at the end of the test under the conditions specified in Clause 11. It shall not have increased by more than 5 K.

21.106 The **flexible part** is subjected to the following test.

For **blankets**, the test of 21.102 is repeated but with the other face of the **flexible part** adjacent to the drum.

For **pads**, the test of 21.103 is repeated but with the other face of the **flexible part** adjacent to the roller.

For **mattresses**, the test of 21.104 is repeated but with the roller moved in the direction of the minor axis. In this case 2 000 cycles are carried out, 1 000 in each of two non-overlapping paths.

21.107 Pads are subjected to a test in a tumbling barrel as shown in Figure 108, their **supply cords** having been cut off at a distance of 100 mm from the **flexible part**. The barrel is turned at a rate of 6 rev/min to 7 rev/min, so that the **pad** falls onto a steel plate twice in each revolution, the number of revolutions being 500.

21.108 Appliances having **heating elements** that are retained in position by bonded layers shall have adequate mechanical strength.

Compliance is checked by the following test.

Six samples of the bonded material, each having dimensions of 100 mm × 130 mm, are cut from the **flexible part**. Three of the samples are cut in the direction of the runs of the **heating element** and the other three samples are cut perpendicular to this direction.

From the ends measuring 100 mm, a strip of the material retaining the **heating element** in position and having a width of 25 mm is cut away from one face at one end of each sample. Another similar strip is removed from the opposite face and at the opposite end of the sample. Any **heating element** situated under the removed strips is also cut away.

NOTE It may be necessary to cut away more than one layer in order to test the bonding of the layers retaining the **heating element**.

Clamps are attached to the full length of the remaining layers of material at both ends of the sample.

The sample is then suspended by one of the clamps and subjected to a total load of 1,25 kg by means of the other clamp. The test is carried out for 1 h at a temperature of 20 °C, and then for 1 h at a temperature of 80 °C.

The test is repeated on six samples taken from the **flexible part** of a new appliance.

The layers retaining the **heating element** in position shall not separate.

21.109 The enclosure of **moisture-proof appliances** consisting of plastic sheeting shall have adequate flexibility under cold conditions.

Compliance is checked by the following test.

The sheeting is cut into 10 rectangular samples, each being 145 mm long and 50 mm wide with the longer dimension perpendicular to any striations resulting from the manufacturing process.

Each sample is folded about its minor axis and allowed to form a loop without creases. It is stapled to a card twice, the staples being placed close together and approximately 30 mm from the edges, as shown in Figure 109.

The test apparatus, which is also shown in Figure 109, has a steel arm that is freely pivoted at one end so that the other end can fall against a steel anvil on which the sample is placed. The mass of the arm assembly is $3,1 \text{ kg} \pm 0,03 \text{ kg}$, the arm and anvil being grooved to clear the staples fixing the samples to the card.

With its arm in the open position, the test apparatus is placed in a top-opening cabinet, the temperature of which is maintained at $-20 \text{ }^\circ\text{C} \pm 2 \text{ }^\circ\text{C}$.

When steady conditions are established, all 10 samples are placed on the floor of the cabinet with their loops uppermost for 1 h. A sample is then placed with its loop uppermost on the anvil of the test apparatus.

NOTE 1 Care is to be taken to ensure that the sample is only handled by means of the card.

The arm of the test apparatus is then allowed to fall and strike the sample from an angle of 85° to the horizontal.

The test is carried out on the other samples as quickly as possible.

No more than two samples shall break into separate pieces.

NOTE 2 The test is not carried out if the appliance has been subjected to the test of 15.102 or if the enclosure is made from reinforced plastic sheeting.

21.110 The enclosure of **moisture-proof appliances** shall have adequate resistance to tearing under normal conditions of use.

For enclosures of plastic sheeting, compliance is checked by the test of 21.110.1.

NOTE The test is not carried out if the appliance has been subjected to the test of 15.102 or if the enclosure is made from reinforced plastic sheeting.

For enclosures of rubberised or similarly treated fabrics, compliance is checked by the tests of 21.110.2 to 21.110.4. For enclosures of seamed fabric, compliance is also checked by the test of 21.110.5.

21.110.1 Five samples of the plastic sheeting, as shown in Figure 110, are conditioned at an ambient temperature of $23\text{ °C} \pm 2\text{ °C}$. The longer dimension is perpendicular to any striations resulting from the manufacturing process.

The shorter edges of each sample are attached over their full length to the clamps of a tensile machine, the sample and the clamps being in the same plane. The clamps are separated at a rate of 50 mm/min until the sample tears. The maximum breaking load is measured.

The average breaking load of the five samples shall be not less than 12,5 N.

21.110.2 A sample of the treated fabric having a diameter of 76 mm is clamped between two disks, each having a diameter not less than 76 mm and a concentric aperture having a diameter of $26\text{ mm} \pm 0,7\text{ mm}$. This assembly is mounted in an apparatus so that water pressure can be applied to the

untreated side of the fabric. The water pressure is gradually increased and is measured when leakage occurs through the fabric. It shall not be less than 410 kPa.

This test is carried out on three samples.

The average value of the pressure shall be at least 490 kPa.

21.110.3 Three sets of three samples, as specified in 21.110.2, are conditioned as follows.

The first set is immersed in boiling water for 1 h and then aged in a heating cabinet at a temperature of $100\text{ °C} \pm 1\text{ °C}$ for 1 000 h. The samples are then immersed again for 1 h in boiling water.

The second set is aged in an oxygen bomb for 168 h, the oxygen having a pressure of approximately 2,0 MPa and a temperature of $80\text{ °C} \pm 1\text{ °C}$.

NOTE The use of the oxygen bomb presents some danger unless handled with care. Precautions should be taken to avoid the risk of explosion due to sudden oxidization.

The third set is aged in an air bomb for 20 h, the air having a pressure of approximately 0,55 MPa and a temperature of $127\text{ °C} \pm 1\text{ °C}$.

The test of 21.110.2 is then carried out on each sample.

The average value of the pressure for each set of samples shall be at least 70 % of the value obtained during the original test of 21.110.2.

21.110.4 Three samples, as specified in 21.110.2, are folded backwards and forwards 10 times.

This test is also carried out on three similar samples that have been conditioned as specified in 21.110.3 for the first set.

The samples shall show no crack, hard spot or other evidence of deterioration.

21.110.5 Twenty samples of seamed fabric, having dimensions of 75 mm × 25 mm, are cut so that the seam lies along the minor axis. They are then divided into four sets of five samples and three of the sets are conditioned as specified in 21.110.3.

All four sets of samples are then subjected to a gradually increasing tensile force until the seam starts to separate.

The average value of the force necessary to separate the seams shall be at least 22 N.

21.111 The insulation of **heating elements** and internal wiring in the **flexible part** shall retain adequate flexibility and insulating characteristics throughout the life of the appliance.

Compliance is checked by the tests of 21.111.1 and by the tests of 21.111.2 and 21.111.3 when the insulation exceeds

- a temperature of 75 °C for **controlled appliances** or a temperature rise of 50 K for other appliances during the test of Clause 11, or
- a temperature of 135 °C for **controlled appliances** or a temperature rise of 110 K for other appliances during the tests of Clause 19.

The tests are carried out on new samples of **heating element** or internal wiring. For appliances having a **bonded enclosure** the samples are taken from a new appliance.

For the test of 21.111.1, one sample measuring approximately 4 m in length is required. For the tests of 21.111.2, at least 12 samples are required, each having a length of 300 mm. For the test of 21.111.3, 12 samples are required each having a length of 300 mm.

The test of 21.111.2 is also applied to the plastic sheath that protects the ends of the **heating element** and is attached to the **flexible part**.

21.111.1 The sample of **heating element** or internal wiring is attached to the equipment shown in Figure 111. This equipment has a carrier with two pulleys, each having a groove with a radius of 4 mm, the diameter at the base of the groove being 25 mm. The pulleys are arranged so that the sample is horizontal where it passes between them.

NOTE 1 For samples not having a circular cross-section, the form of the groove in the pulley is suitably modified.

The sample is stretched over the pulleys, each end being loaded with a mass of 0,25 kg. If necessary, the mass at each end is increased in steps of 0,1 kg in order to ensure that the wires leaving the pulleys are parallel to each other. Restraining clamps are positioned so that the pull is always applied by the mass in the opposite direction to which the carrier is moving.

The carrier is moved by a means of a chain over a distance of 1 m at a constant speed of approximately 0,33 m/s for 25 000 cycles.

NOTE 2 A cycle is two movements, one in each direction.

The sample shall not break during the test.

NOTE 3 A monitoring current not exceeding 50 mA may be passed through the sample during the test.

For **PTC heating elements**, the power input is measured before and after the test. The measurement is made with the **heating element** suspended vertically in free air and supplied at the **rated voltage** of the appliance. Both measurements are carried out at the same ambient temperature and when the power input has stabilized. The power input shall not increase during the test.

The sample is then immersed in water containing approximately 1 % NaCl. A d.c. voltage of approximately 500 V is applied between the conductor and the saline solution.

The insulation resistance is measured 1 min after immersion and shall be at least 1 M Ω .

21.111.2 The conductors are pulled out from 12 samples of **heating element** or internal wiring. If this is not possible, the insulation is slit longitudinally, the conductor is removed and the insulation allowed to close.

Six of the samples are conditioned by suspending them vertically so that they hang freely in a heating cabinet at a temperature of $125\text{ °C} \pm 2\text{ °C}$ for 336 h. The samples are removed from the cabinet and allowed to cool down to room temperature. When the material has stabilized, the length of the samples is measured and shall not be less than 90 % of the original length.

NOTE 1 PVC material is considered to have stabilized by 16 h after removal from the cabinet.

NOTE 2 The heating cabinet should have forced air circulation in order to ensure that there is no temperature gradient over the length of the samples.

The 12 samples are placed in a tensile machine in turn so that the length between the clamps is at least 50 mm. The machine is operated at a uniform speed of $500\text{ mm/min} \pm 50\text{ mm/min}$. The force and elongation at the instant of rupture are determined.

Results obtained from any sample that ruptured at a force differing from the average value by more than 10 %, and from samples that ruptured within a distance of 15 mm from the clamp, are disregarded. Additional samples are tested in order to obtain 12 valid results.

The elongation of each of the unconditioned samples shall not be less than 100 % and their tensile strength shall not be less than 8,75 MPa.

The average value of both the elongation and the tensile strength of the conditioned samples shall not be less than 75 % of the average value determined for the unconditioned samples.

21.111.3 A 10 mm length of insulation is removed from each end of 12 samples of **heating element** or internal wiring.

Six of the samples are wound in a close helix of six turns on a metal mandrel having a diameter approximately equal to the external diameter of the samples,

and together with the remaining six samples are placed in a heating cabinet at a temperature of $125\text{ °C} \pm 2\text{ °C}$ for 336 h. The samples are removed from the cabinet and allowed to cool down to room temperature.

When the material has stabilized, the other six samples are also wound on the mandrel in the same way.

NOTE 1 PVC material is considered to have stabilized by 16 h after removal from the cabinet.

NOTE 2 The heating cabinet is to have forced air circulation in order to ensure that there is no temperature gradient over the length of the samples.

The mandrel is immersed for 1 h in water containing approximately 1 % NaCl. The samples are then subjected to a test voltage of 1 000 V, for **class II appliances** and 500 V for **class III appliances**. The voltage is applied for 1 min between the conductors and the solution. There shall be no breakdown.

The samples are unwound from the mandrel and inspection shall show that there are no visible cracks.

21.112 PTC heating elements shall be resistant to crushing.

Compliance is checked by the following test.

The **flexible part** is fully supported by a piece of plywood 20 mm thick and supplied as specified in 11.4. When steady conditions are established, the temperature of the **heating element** is measured. A block having dimensions of 100 mm × 300 mm and a mass of 80 kg is applied for 5 min to the surface in the most unfavourable place. After removing the block, the appliance is again operated until steady conditions are established and the temperature of the **heating element** is measured. The temperature of the **heating element** where the block has been applied shall not have increased by more than 10 K.

NOTE 1 The edges of the block in contact with the **flexible part** are rounded.

NOTE 2 The most unfavourable place to apply the block is usually at a loop in the element.

22 Construction

This clause of Part 1 is applicable except as follows.

22.101 The insulation of **heating elements** and internal wiring shall be integral with the conductors in **flexible parts**, for other than **class III construction**.

Compliance is checked by inspection.

22.102 There shall be no connection in the **heating element**, except where it is connected to **thermostats, thermal cut-outs**, and similar components.

Compliance is checked by inspection.

22.103 The **flexible part** shall be constructed so that **heating elements, electro-conductive textiles** and internal wiring are retained in their intended position. No part of the **heating element** shall cross over another part of the **heating element**.

If the **heating element** or **electro-conductive textile** is supported by a separate layer of material, this material shall be firmly secured to the enclosure to prevent internal rucking.

Crossing of internal wiring shall be avoided as far as possible. When this is unavoidable, the wiring shall be secured in order to prevent any relative movement.

Compliance is checked by inspection.

NOTE This requirement does not apply to signal conductors dissipating less than 150 mW/m.

22.104 There shall be no significant change in the position of the **heating elements** or busbars if the stitching retaining them in position is broken.

Compliance is checked by inspection after breaking the thread in the most unfavourable place.

22.105 Thermostats and **thermal cut-outs** incorporated in the **flexible part** shall be individually enclosed in insulating material.

Compliance is checked by inspection.

22.106 Ruck-resistant blankets shall be constructed so that rucking of the **flexible part** is unlikely.

Compliance is checked by the following test.

Any stiffening means is removed if it is not representative of the construction of the **flexible part**.

The **blanket** is operated at **rated power input** and under **normal operation** for 3 h. It is then removed from the sheets of thermal insulation and laid flat on a horizontal surface while still connected to the supply mains. The **flexible part** is positioned so that a corner touches the edge of the surface with a diagonal perpendicular to it.

A wooden board, having dimensions of 1 m x 1 m and a thickness of 20 mm, is placed over the **blanket** and positioned so that the edge of the board aligns with the edge of the surface. The **flexible part** and board are then slid together until the edge of the board overhangs the edge of the surface by 300 mm.

The deflection X , in metres, of the overhanging corner of the **flexible part** is measured as shown in Figure 112. The force F , in newtons, required to lift the overhanging corner to the lower surface of the board is then measured.

The measurement is repeated on the other corners, except for any corner containing an appliance inlet or cord entry.

The ruck-resistance is calculated from F/X . It shall be at least 2,5 for each corner.

22.107 Underblankets, other than **blankets** having a ruck-resistance greater than 1,2 measured as specified in 22.106, shall be provided with means to prevent rucking. The means used for this purpose shall be permanently attached, ensure that the **blanket** cannot ruck in any direction and not damage the **blanket** in normal use. If tapes or similar means are provided, they shall be long enough and positioned so that the **blanket** can be readily and effectively secured to the maximum size of mattress for which it is intended. Pins shall not be used.

Compliance is checked by inspection and by manual test.

22.108 The dimensions of **detachable covers** shall be greater than those of the **flexible part**.

Compliance is checked by measurement after laundering the cover three times in accordance with the instructions.

22.109 Control units intended to stand on a table shall not have openings on the underside that could allow small items to penetrate and touch **live parts**.

Compliance is checked by inspection and by measuring the distance between the supporting surface and **live parts** through openings. This distance shall be at least 6 mm.

22.110 Control units that automatically switch from a high heat output to a low heat output after a pre-set time shall not automatically switch back to the high heat output setting.

Compliance is checked by inspection and during the test of 11.101.

22.111 Fuse links or **thermal links** that are incorporated to protect the **flexible part** against overheating or ignition shall not be replaceable by the user.

Compliance is checked by inspection.

22.112 Duvets shall have adequate thermal properties.

Compliance is checked by the following test.

The **duvet** is placed on a sheet of thermal insulation having a thickness of 72 mm as specified in Annex AA. A heat source as specified in Annex AA is placed between the thermal insulation and the **duvet**. When steady conditions are established, the temperature rise shall exceed 40 K.

22.113 Appliances, shall incorporate a manual switch to control the **flexible part**. The switch shall be constructed to prevent its actuating member from rotating continuously in the same direction.

Switches and **control units** in flexible cords shall have an **off position** at both ends of the travel of the actuating member, unless an indicator lamp is incorporated to show when the switch is in an on position.

Compliance is checked by inspection.

22.114 Flexible parts comprised of **electro-conductive textile** shall be of **class III construction**.

Compliance is checked by inspection.

23 Internal wiring

This clause of Part 1 is applicable.

24 Components

This clause of Part 1 is applicable except as follows.

24.1.3 Modification:

Switches are tested for 6 000 cycles of operation.

24.1.4 Modification:

Thermostats are operated for 100 000 cycles of operation and **self-resetting thermal cut-outs** for 10 000 cycles of operation.

24.2 Modification:

Appliances may be fitted with switches and **control units** in flexible cords.

25 Supply connection and external flexible cords

This clause of Part 1 is applicable except as follows.

25.2 Addition:

Blankets for double beds having two separate **heated areas** may have two means of connection to the supply.

25.5 Addition:

Type Z attachment is allowed.

Non-detachable flexible cords shall be connected to the **flexible part** only by **type Y attachment** or **type Z attachment**.

25.7 Addition:

Light polyvinyl chloride sheathed cords may be used, irrespective of the mass of the appliance.

Natural rubber sheathed cords shall not be used.

25.8 Modification:

Cords having a nominal cross-sectional area of 0,5 mm² may be used, irrespective of their length.

25.15 Modification:

Flexible cords connected to the **flexible part** are subjected to a pull force of 100 N that is only applied three times for 1 min each time, the longitudinal measurement not being made. The **flexible part** is securely held by means of

clamps that grip the entire length of the edge opposite the cord entry. If the cord enters at a corner, the clamps grip the entire length of both edges adjacent to the opposite corner.

Flexible cords connected to switches and **control units** are subjected to a pull force of 100 N and a torque of 0,1 Nm.

25.23 Addition:

Interconnection cords for **blankets** and **mattresses** are not required to be sheathed.

If an **interconnection cord** has more than two conductors, the current density of each conductor shall not exceed 12 A/mm² and the sum of the cross-sectional areas shall be at least 1 mm².

If non-standardized flexible cords are used, their electrical and mechanical properties shall be at least equal to those specified in IEC 60227.

NOTE 101 When the ends of the **heating element** are contained in a plastic sheath attached to the **flexible part**, the requirements related to current density and those of IEC 60227 do not apply.

26 Terminals for external conductors

This clause so that it is unlikely to be exposed to pollution during normal use of the appliance. of Part 1 is applicable.

27 Provision for earthing

This clause of Part 1 is applicable.

28 Screws and connections

This clause of Part 1 is applicable except as follows.

28.2 Addition:

The requirement does not apply to the connections to the **heating elements** and **electro-conductive textiles**.

29 Clearances, creepage distances and solid insulation

This clause of Part 1 is applicable except as follows.

29.2 Addition:

The microenvironment of the flexible part is pollution degree 3 unless the insulation is enclosed or located so that it is unlikely to be exposed to pollution during normal use of the appliance.

29.3 Addition:

The requirement does not apply to the **flexible part**.

30 Resistance to heat and fire

This clause of Part 1 is applicable except as follows.

30.1 Addition:

The requirement does not apply to the enclosure of the **flexible part**.

Modification:

Parts of resilient plastic material fitted to the **flexible part** are subjected to the pressure test of 24.1.3 of IEC 60320-1 instead of the ball pressure test of IEC 60695-2-10.

NOTE 101 Examples of resilient plastic material are interconnection couplers and connection blocks.

30.2 Addition:

The enclosure of the **flexible part** is not tested.

30.2.1 Addition:

Electro-conductive textiles shall comply with the requirements specified in ISO 9772 for category HBF material.

30.2.2 Not applicable.

30.2.3.2 Addition:

The needle-flame test is not carried out on the enclosure of the **flexible part**.

30.101 The enclosure of the **flexible part** shall be resistant to ignition, unless the appliance incorporates means to prevent overheating resulting from the arcing of conductors.

Compliance is checked by the test of

- 30.101.1, for assessing the resistance to ignition of the **flexible part**, or
- 30.101.2, for appliances incorporating means to prevent overheating resulting from the arcing of conductors.

30.101.1 Six samples, having dimensions of 100 mm × 200 mm, are cut from the enclosure so that their shorter sides are parallel with the runs of the **heating element**. They are selected from parts of the enclosure so that no two samples contain the same warp thread or the same weft thread. If this is not possible, the samples are selected so that the same threads do not appear in more than two samples. Any pieces of **heating element** and trimming are removed from the samples.

The test equipment, as shown in Figure 113, has two brass electrodes 3 mm in diameter that are supported by brass pillars mounted on a base of insulating material so that their axes are aligned. The base also supports a platform of insulating material, having dimensions of 100 mm × 100 mm, and located

centrally between the brass pillars. Provision is made for the height of the platform to be adjusted.

One of the electrodes is fixed in position while the other electrode is movable, thus allowing the sample to be inserted. The tip of the fixed electrode has an angle of 45° . The electrode is positioned so that the point furthest from the brass pillar is at the top and at a distance of approximately 3 mm from the centre of the platform. The movable electrode has a flat end.

The lower part of a hardwood mask, as shown in detail A of Figure 113a, is placed on the adjustable platform in the position indicated.

The test equipment, including the upper part of the mask as shown in detail B of Figure 113a, is placed in a heating cabinet having a door with an inspection window and air circulated by natural convection. The electrodes are connected in series with an adjustable non-inductive resistor to a supply having a sinusoidal output voltage of 10 kV and a characteristic such that the output voltage does not decrease by more than 100 V when a current of 1 mA is flowing.

The temperature of the heating cabinet is raised to $65\text{ }^\circ\text{C} \pm 2\text{ }^\circ\text{C}$. The electrodes are then short-circuited and the resistor adjusted so that a current of 1 mA flows. The supply is then disconnected and the samples are placed in the cabinet for a period of 3 h.

Without removing the equipment from the heating cabinet, the movable electrode is withdrawn and one sample is pulled over the fixed electrode so that the electrode is situated centrally in the space normally occupied by the **heating element**. The sample is adjusted so that its end is approximately level with the edge of the adjustable platform. The movable electrode is then inserted into the other end of the element space and is fixed so that the distance between the electrodes is $6,0\text{ mm} \pm 0,1\text{ mm}$. The sample is smoothed out and the upper part of the mask is placed in position. The door of the heating cabinet is then closed for a further period of 5 min in order to stabilise the temperature.

The supply is switched on and sparks are allowed to pass between the electrodes for a period of 2 min. If the sample ignites, the time from the instant of switching on until the flame reaches the inner edge of the mask is recorded, any ignition of surface fibres which lasts no more than 3 s being ignored. If the sample does not ignite, a time of 120 s is recorded.

The sample is then removed and repositioned between the electrodes with the other surface uppermost and so that the opposite end is subjected to the test.

The test is repeated on the other five samples.

If any time recorded is less than 30 s, the complete test is repeated on a second set of six samples. In this case, no sample shall have a recorded time less than 30 s.

The average of the 12 values recorded is calculated and shall not be less than 80 s. All values differing by more than 30 s from the average are ignored and, if necessary, the average of the remaining values is recalculated.

30.101.2 A suitable length of the conductor is exposed and the insulation of the conductor is removed over a length of 25 mm. This part of the conductor is bent in a radius of 75 mm and immersed in a non-conductive liquid having a temperature of $230\text{ °C} \pm 2\text{ °C}$, the appliance being supplied at **rated voltage**. Within 30 s the protection system shall operate so that the power input of the **flexible part** does not exceed 1 W.

The conductor is withdrawn from the liquid when the protection system has operated. If the power input of the **flexible part** subsequently increases above 1 W, the test is carried out 100 times or until the power input is permanently reduced below 1 W, whichever occurs first.

30.102 The insulation of **heating elements** and internal wiring within the **flexible part** shall be sufficiently resistant to abnormal heat and to fire.

NOTE This requirement also applies to material used to insulate connections.

Compliance is checked by the following test.

A sample of the **heating element** or internal wiring at least 150 mm long is supported by a grid inclined at 45° . The grid is formed from parallel wires 0,6 mm in diameter and spaced 20 mm apart. The sample is positioned perpendicular to the horizontal wires and centrally between the other wires. A second grid of similar dimensions is placed on top of the sample so that its horizontal wires are displaced by 10 mm from the horizontal wires of the first

grid. The wires of both grids that are parallel to the sample are aligned with each other.

The grid is mounted at the centre of a three-sided metal screen in a substantially draught-free location. The screen is approximately 900 mm high, 450 mm wide and 300 mm deep, of rectangular plan with open front and closed top.

A needle flame, as specified in IEC 60695-2-2, is applied to the sample and is maintained until the insulation ceases to burn.

The length of the sample damaged by fire shall not exceed 65 mm, measured from the point where the flame is applied.

31 Resistance to rusting

This clause of Part 1 is applicable.

32 Radiation, toxicity and similar hazards

This clause of Part 1 is applicable..



IEC 1 474/98

Figure 101 – Symbol for "Do not use folded or rucked"



IEC 1 475/98

Figure 102 – Symbol for "Do not insert pins"

Figure 103 – Void

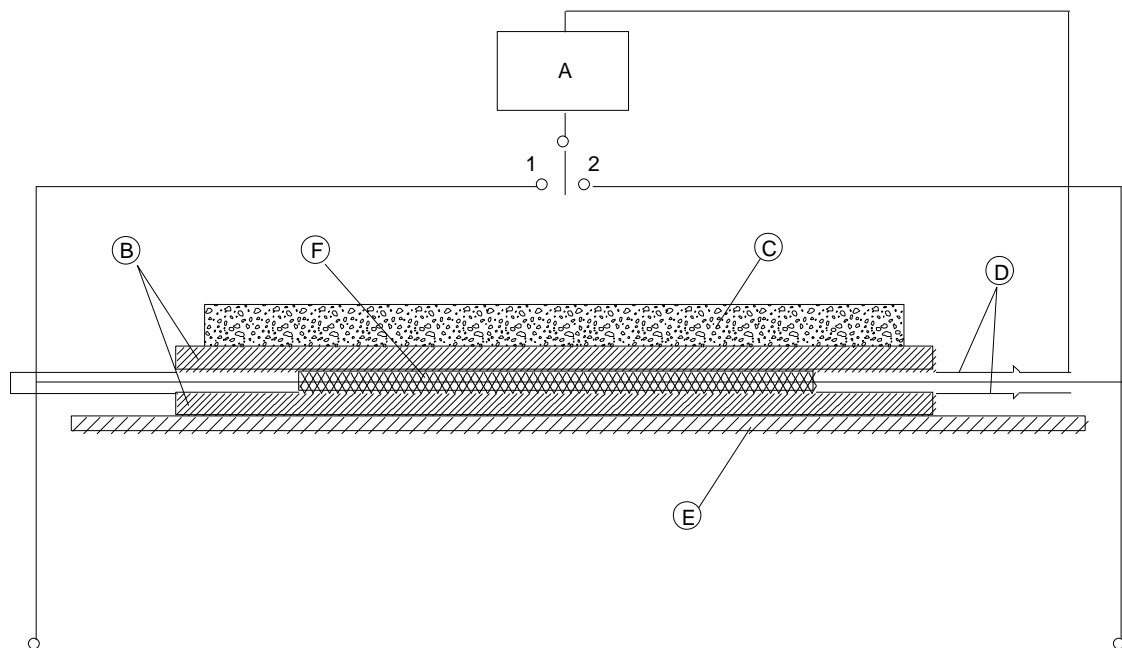

IEC 2209/02

Key

- A Circuit of Figure 4 of IEC 60990
- B Sheets of thermal insulation
- C Uniformly distributed load
- D Aluminium foil
- E Plywood base
- F **Flexible part**

Figure 104 – Arrangement for measuring leakage current and electric strength of the flexible part

SAUDI ARABIAN STANDARD

SASO GSO IEC 60335-2-17/2008

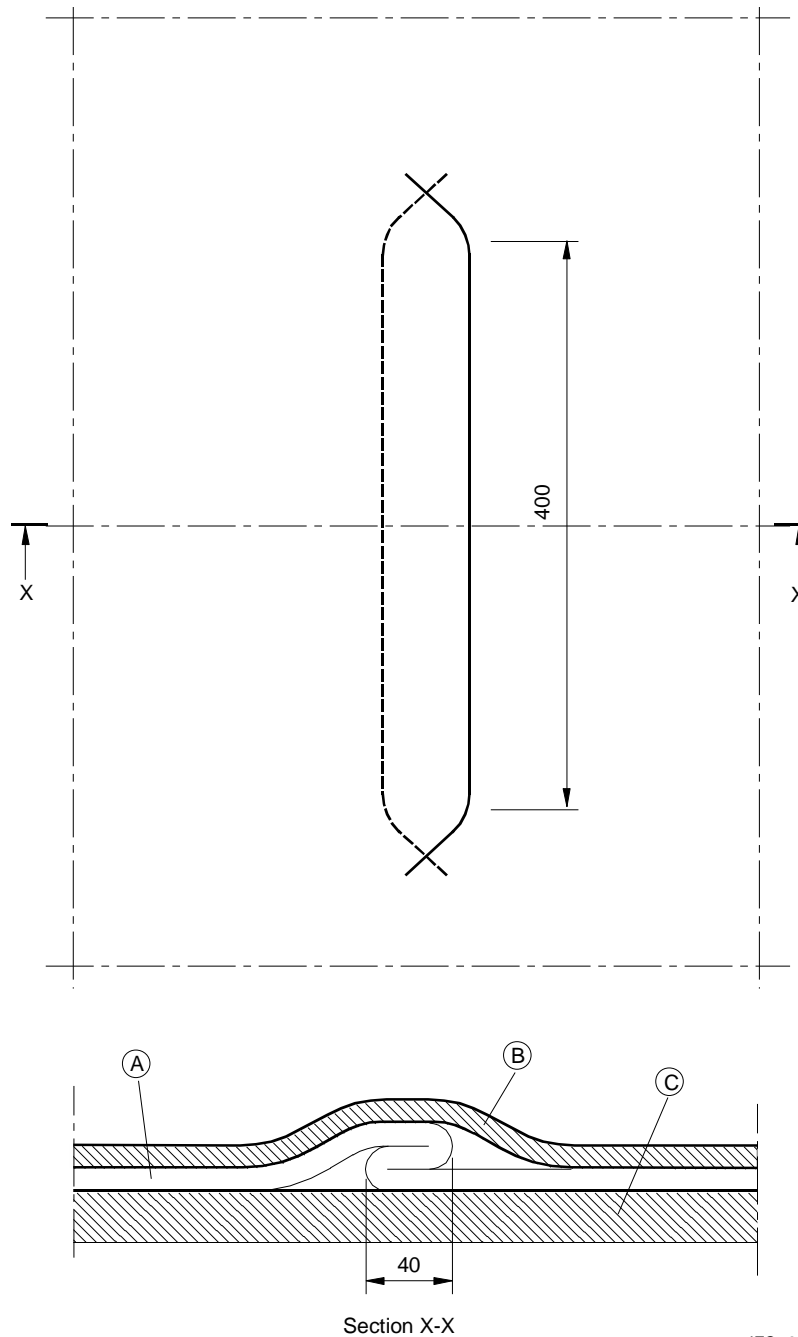

IEC 2210/02

*Dimensions in millimetres***Key**

- A Flexible part
- B Upper sheet of thermal insulation
- C Lower sheet of thermal insulation

Figure 105 – Arrangement for the three-thickness fold test

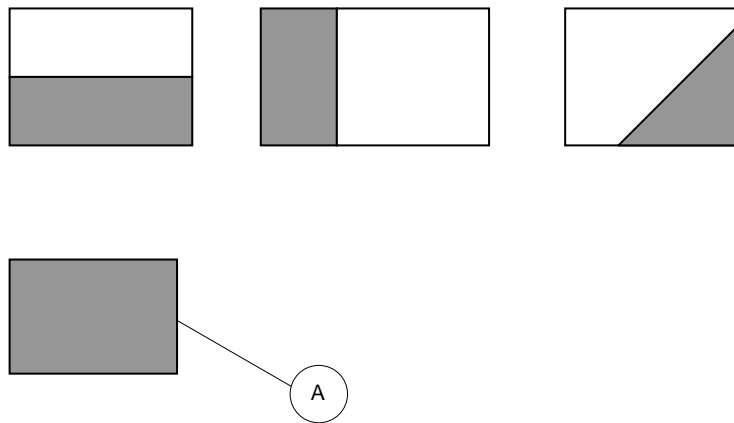

IEC 2710/05

Key

A Thermal insulation

Figure 106 – Examples showing the position of the thermal insulation on ruck-resistant blankets and mattresses

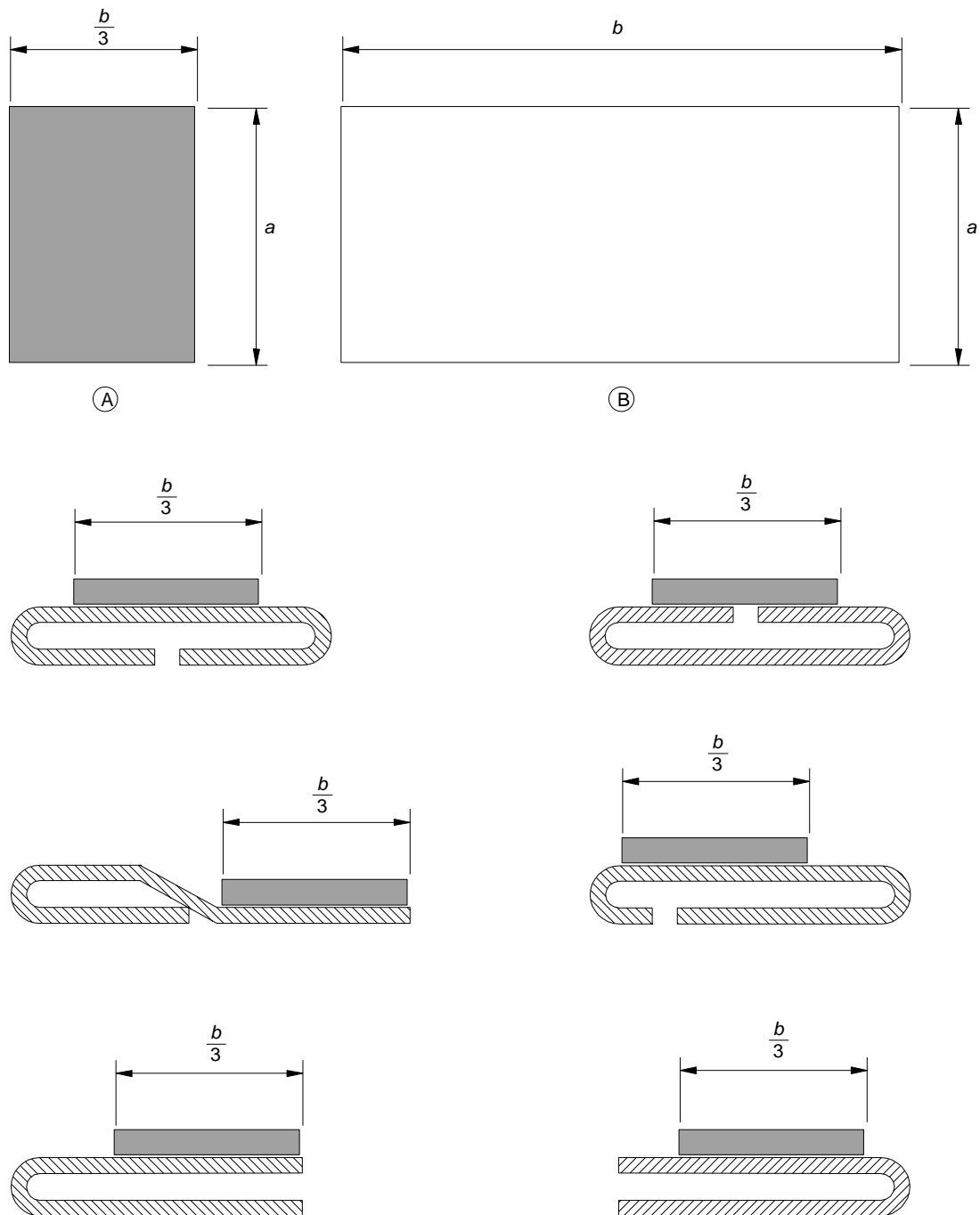

IEC 2212/02

Key

A Thermal insulation

B Pad

Figure 107 – Examples of folds and the position of the thermal insulation on pads

SAUDI ARABIAN STANDARD

SASO GSO IEC 60335-2-17/2008

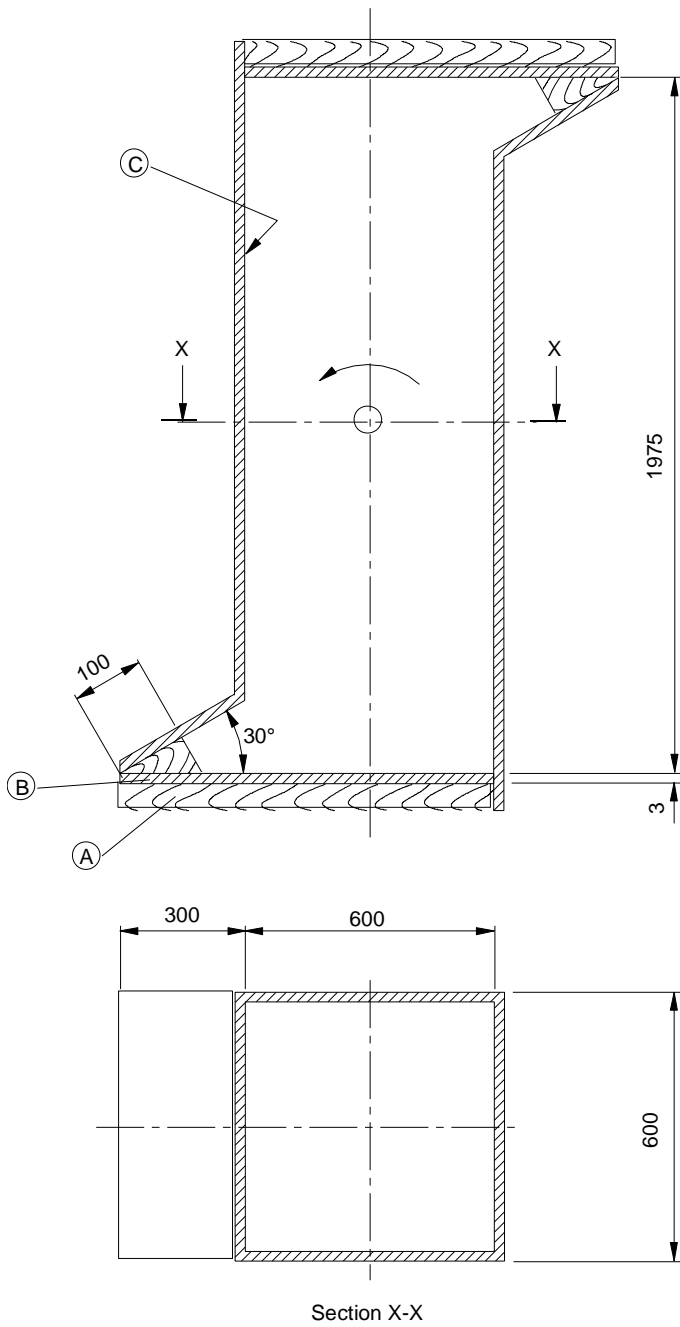

IEC 2213/02

*Dimensions in millimetres***Key**

- A Wooden support
- B Steel plate
- C Smooth metal sides

Figure 108 – Tumbling barrel for testing the mechanical strength of pads

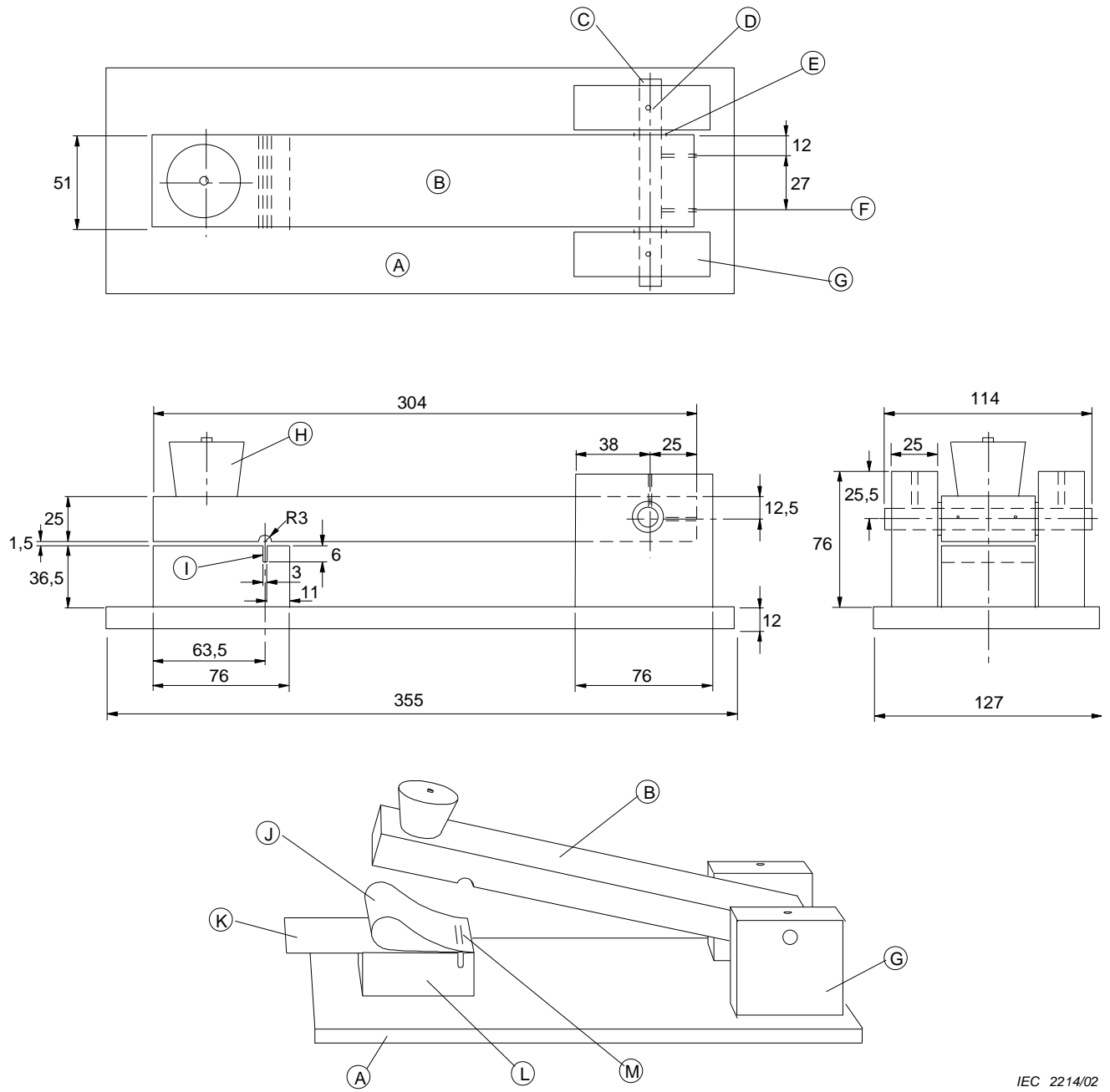

Dimensions in millimetres

IEC 2214/02

Key

- | | |
|-----------------------|------------------------------|
| A Base | B Arm |
| C Loose fitting shaft | D Countersunk oil hole |
| E Machined washer | F Tapped holes for set screw |
| G Arm support | H Knob |
| I Slot | J Sample |
| K Card | L Anvil |
| M Staples | |

SAUDI ARABIAN STANDARD	SASO GSO IEC 60335-2-17/2008
-------------------------------	-------------------------------------

Figure 109 – Impact apparatus for testing enclosures of moisture-proof appliances

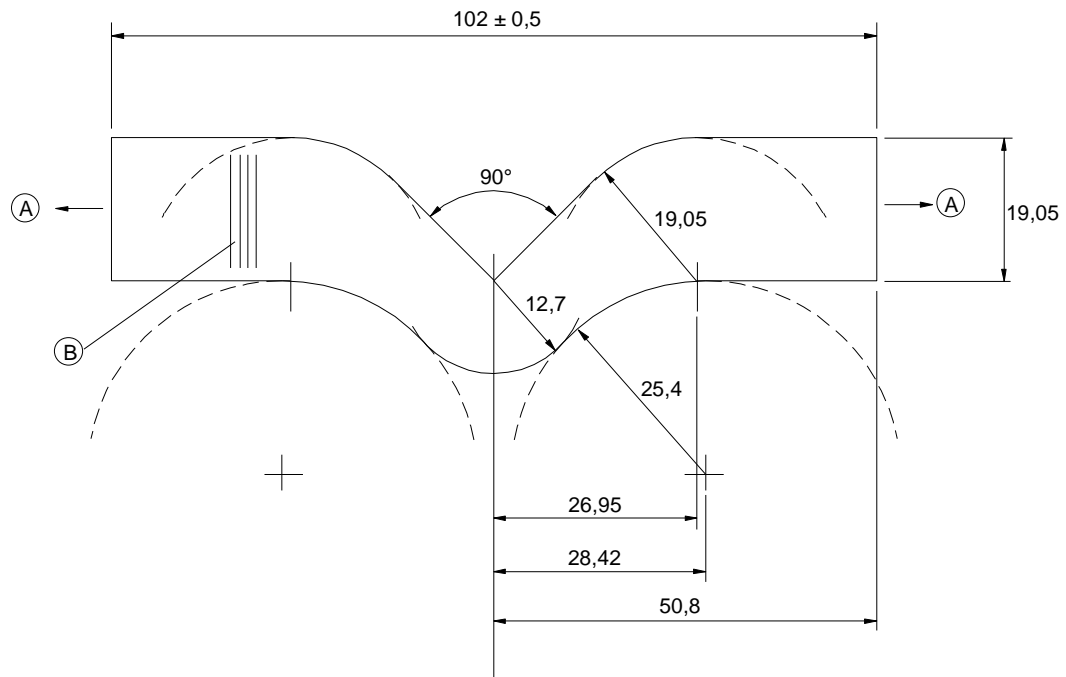

IEC 2215/02

*Dimensions in millimetres***Key**

A Direction of pull

B Direction of striations

Figure 110 – Shape of the sample for the tear resistance test

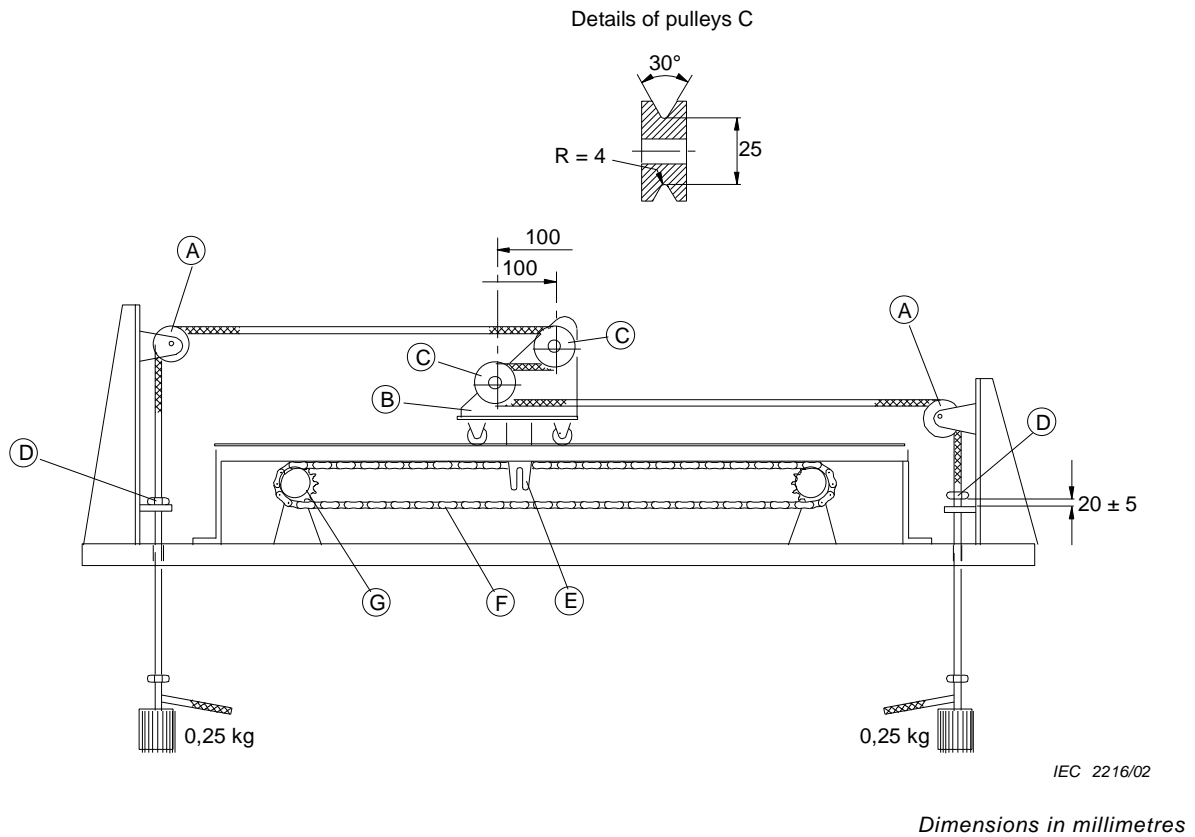
**Key**

- A Pulley having a diameter > 50 mm
- B Carrier
- C Grooved pulley
- D Restraining clamp
- E Engagement pin
- F Chain having a pitch of 12,7 mm
- G Sprocket having 20 teeth with a pitch circle diameter of 88,9 mm

Figure 111 – Equipment for flexing heating elements and internal wiring

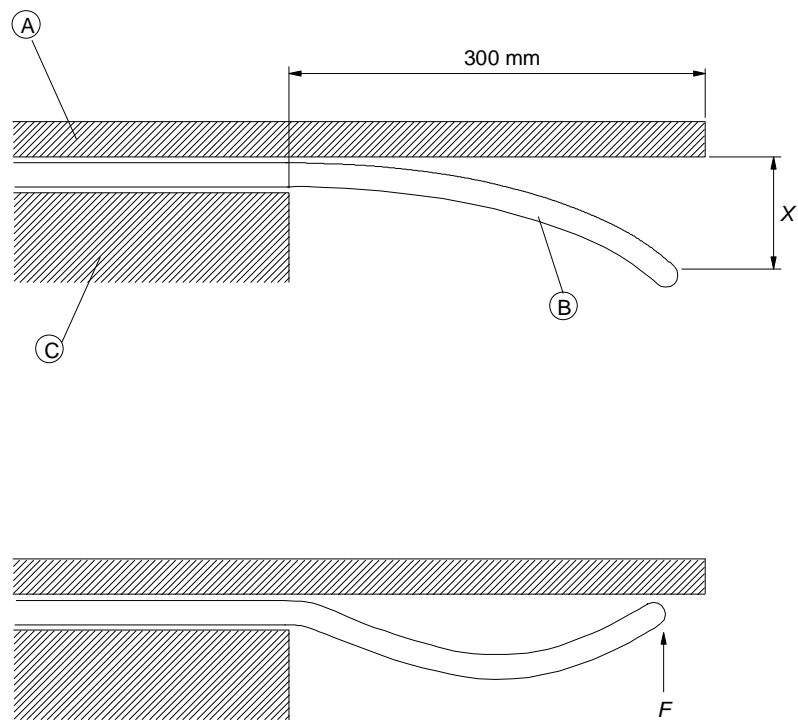

IEC 2217/02

Dimensions in millimetres

NOTE X is the deflection in metres

F is the force in newtons

Key

- A Wooden board
- B Blanket
- C Horizontal surface

Figure 112 – Arrangement for the rigidity test of ruck-resistant blankets

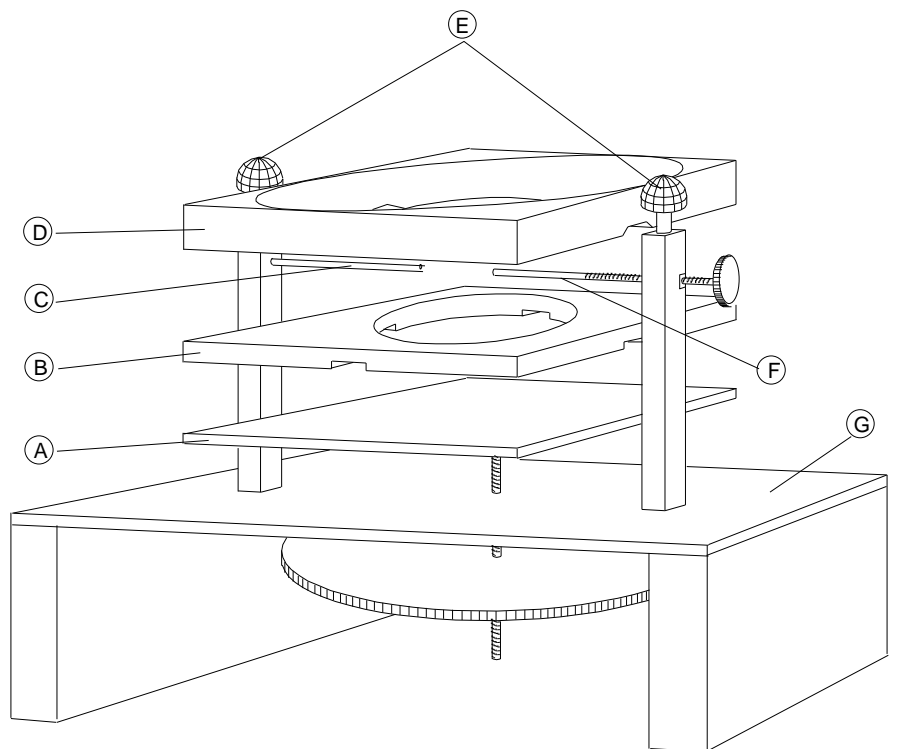

IEC 2218/02

Key

- A Adjustable platform
- B Lower part of mask (see detail A of Figure 113a)
- C Fixed electrode
- D Upper part of mask (see detail B of Figure 113a)
- E Terminals
- F Movable electrode
- G Base plate

Figure 113 – Equipment for the spark ignition test

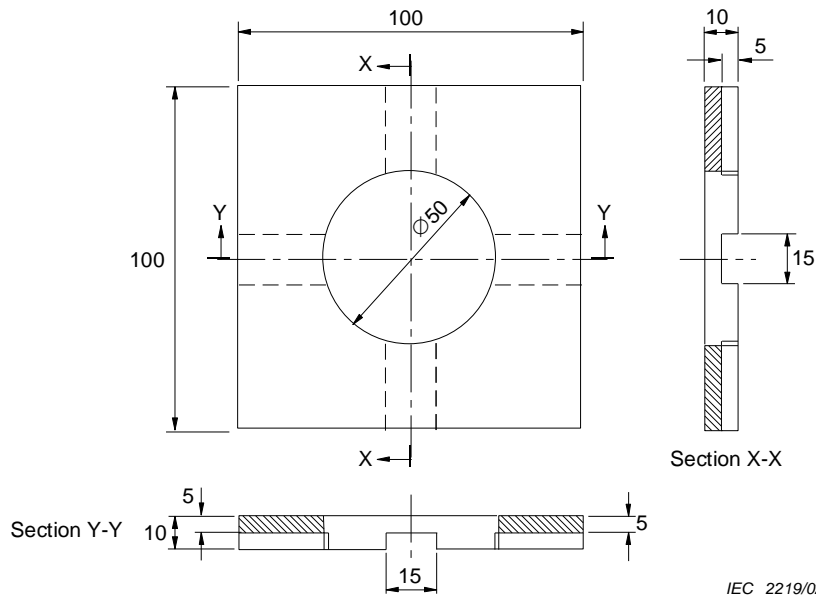

IEC 2219/02

Dimensions in millimetres

Detail A – Lower part of mask

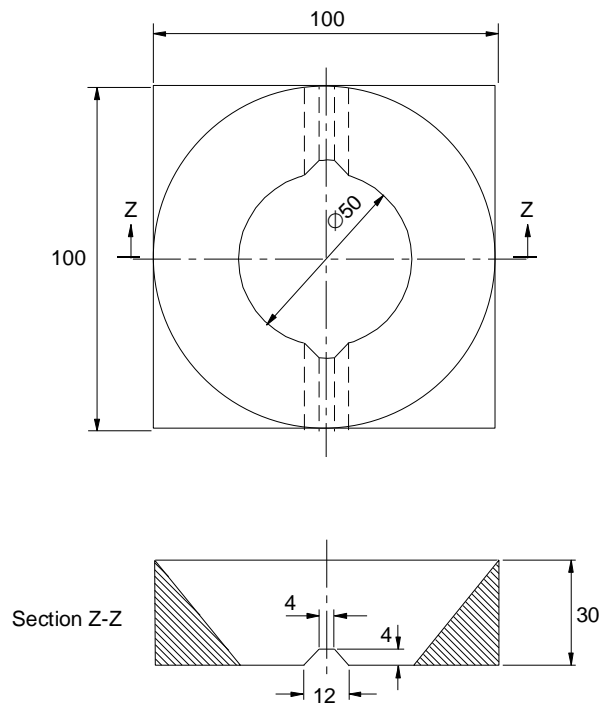

IEC 2220/02

Dimensions in millimetres

Detail B – Upper part of mask

NOTE The mass of the upper part of the mask is approximately 100 g, which is achieved by modifying its thickness

SAUDI ARABIAN STANDARD	SASO GSO IEC 60335-2-17/2008
-------------------------------	-------------------------------------

Figure 113a – Details of the mask

Annexes

The annexes of Part 1 are applicable except as follows.

Annex A (informative)

Routine tests

This annex of Part 1 is applicable except as follows:

A.2 Electric strength test

Addition:

An additional electric strength test is carried out between **live parts** and **accessible parts** of the **flexible part**, other than parts operating at **safety extra-low voltage**. The test voltage is determined from Table A.101.

Table A.101 – Test voltages

Type of test voltage	Test voltage V	
	Rated voltage	
	≤150 V	>150 V and <250 V
a.c.	2 000 + X	2 500 + X
d.c.	3 000 + X	3 750 + X

The value of X is determined as follows.

The **flexible part** is opened and the insulation of the **heating element** is removed over a length of 5 mm to expose the conductor. The **heating element** is then reinserted into the enclosure of the **flexible part**. A test voltage of 1 000 V (1 500 V d.c.) is applied between the conductor and the external surface of the **flexible part**. The voltage is increased in steps of 500 V (750 V d.c.) until breakdown occurs. The value of X is the test voltage before breakdown occurs.

NOTE 101 If the **flexible part** incorporates a permanent outer enclosure made of electrical insulating material such as PVC, the value of X is determined with this enclosure removed.

NOTE 102 Acceptable methods of applying the test voltage are

- passing the **flexible part** between rollers;
- passing the **flexible part** on a conveyor by a metal plate;
- placing the **flexible part** between metal plates;
- sweeping a chain wire brush over the **flexible part**.

A.3 Functional test

Addition:

The functional test includes

- a check that the resistance of the **heating element** is within the tolerance;
- a check that no current flows when the control is in the **off position**.

NOTE 101 The tolerance selected is to ensure that the power input deviation of Clause 10 is not exceeded.

Annex AA
(normative)

Specification for the thermal insulation

The thermal insulation has the following composition.

Open-cell polyether:

Cell count 18^{+2}_0 per cm;

Specific mass $30 \text{ kg/m}^3^{+10}_0$ %;

Hardness 120 N to 170 N at 40 % impression, measured according to ISO 2439.

In order to determine the thickness of the sheets of thermal insulation to be used, an evenly distributed heat source, having dimensions of 1 m × 1 m and a power input of $100 \text{ W} \pm 2 \text{ W}$, is placed centrally between two layers of thermal insulation having dimensions at least 1,2 m × 1,2 m.

An oxidized copper plate having dimensions 65 mm × 65 mm × 0,5 mm to which a fine-wire thermocouple is attached, is placed at the centre of the upper surface of the heat source.

The heat source is connected to the supply and the temperature rise is measured. The thickness of the thermal insulation is established when the following steady temperature rise values are recorded:

- 25 K ± 1 K, for **overblankets**;
- 60 K ± 2 K, for **underblankets, pads and mattresses**.

If the thickness of the thermal insulation below the heat source is 2 d, the approximate thickness of the thermal insulation covering the heat source is

- 0,2 d, corresponding to a temperature rise of 25 K;
- d, corresponding to a temperature rise of 60 K.

NOTE 1 The dimension d is approximately 36 mm.

NOTE 2 The heat source may consist of a conductive sheet or two cotton sheets between which a heating conductor is uniformly arranged, so that the distance between adjacent runs does not exceed 20 mm.

NOTE 3 Slight adjustments of the heat discharge can be achieved by adding a few sheets of suitable textile material.

NOTE 4 No additional load is applied to the upper surface of the thermal insulation.

Annex BB
(normative)

Equipment for the mechanical strength test for blankets

The equipment, as shown in Figure BB.1, has a rotating drum 160 mm in diameter and of sufficient length to accommodate the length of the blanket. Solid rubber spheres, having a diameter of 60 mm \pm 2,5 mm and a hardness of 40 IRHD to 50 IRHD, are cut and attached to the drum so that they project above the surface by 25 mm. The spheres are arranged in six rows equally spaced around the circumference of the drum, the spheres in each row being 320 mm apart. The spheres are positioned mid-way between pairs of spheres in adjacent rows, as shown in Figure BB.2. The drum is free to rotate about its carrier shaft.

Below the drum, a 25 mm square bar is attached in such a way that it can freely rotate in carriers mounted in guide rails that are free to move up and down. Weights can be attached to the carriers so that the total mass of the bar and carriers can be adjusted.

Smooth hardwood cylinders, having a diameter of 65 mm and a length of 140 mm, are positioned above the drum. Each cylinder is locked to a pair of arms that pivot on an axis at a distance of 160 mm from the axis of the cylinder. The cylinders are positioned so that every sphere passes under the centre of a cylinder. The pivot bar is positioned so that when the cylinders are in contact with the top of the drum, the axis of the arms is at an angle of 25° to the horizontal. The force exerted by each cylinder on the drum is 5,1 N.

A sprocket having a pitch circle diameter of 230 mm is secured to each end of the drum carrier shaft. Endless chains, that carry a driving bar, pass over these sprockets and round the square bar in its lowest position.

The clamping bar, as shown in Figure BB.3, is attached to the driving bar by means of 3,5 mm diameter screws. Wire swivels are attached to the lower edge of the clamping bar as shown in the figure.

The **blanket** is secured over its entire length to the wire swivels by means of clips and adjustable webbing straps. It is then passed over the drum, under the square section bar and clipped to the other end of the webbing straps. The **blanket** and straps form a continuous belt that is tensioned by adding weights

to the carriers so that the total mass of the bar assembly and carriers is 6 kg/m of attached edge of the **blanket** or 6,5 kg, whichever is greater. The webbing straps are adjusted so that the square bar and carriers are lifted 50 mm above their rest position. The tension on the straps is not subsequently altered. The straps are positioned so that they pass between the spheres on the drum.

NOTE 1 Sufficient straps are provided to prevent the **blanket** from rucking.

NOTE 2 Any **supply cord** is attached to the driving bar in such a way that it will not affect the result of the test.

NOTE 3 Means are provided to raise the cylinders when the driving bar passes over the drum to avoid damaging the equipment.

NOTE 4 The driving bar is separately driven. Both the drum and square bar are rotated by means of the blanket passing over them.

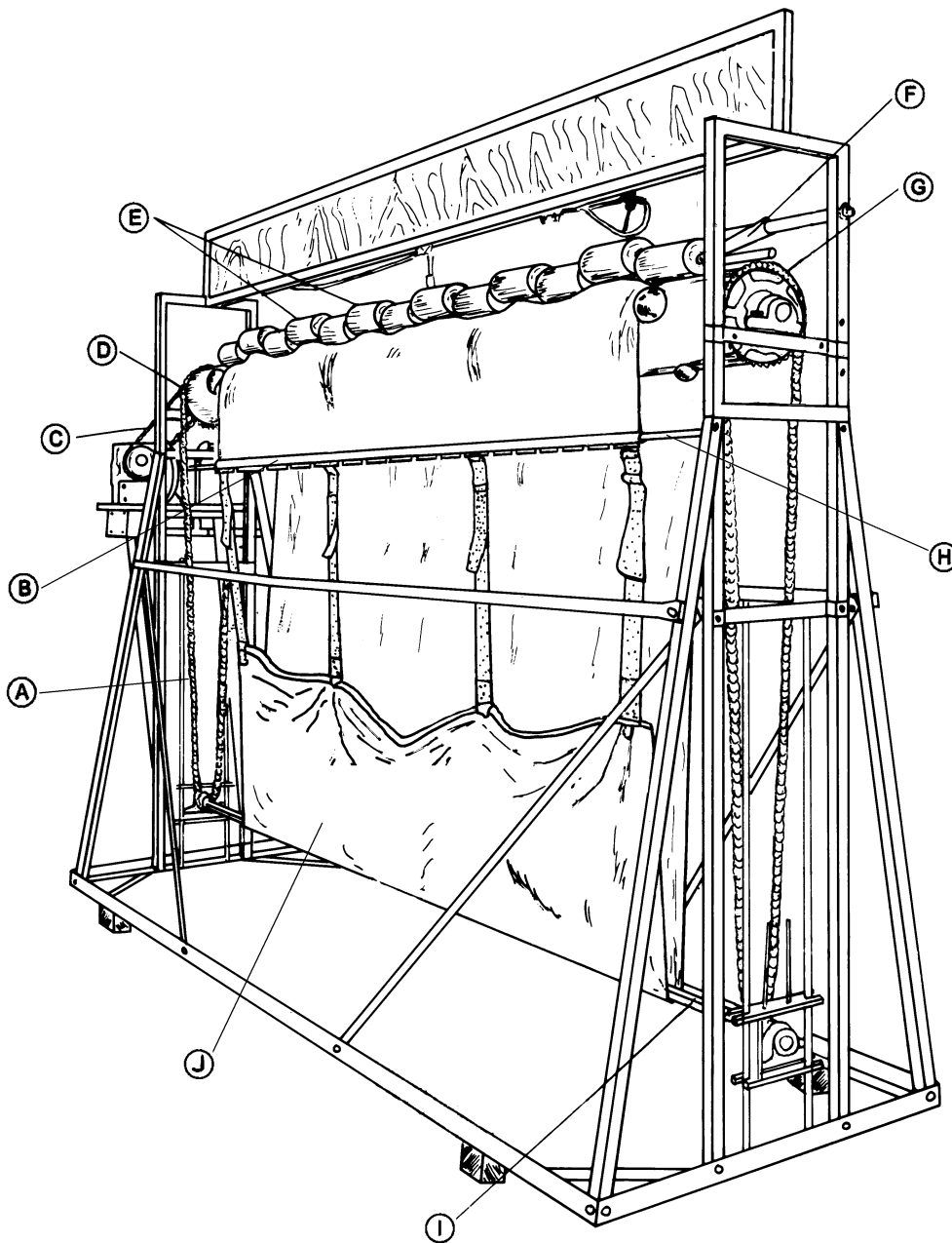

IEC 2221/02

Key

- | | | | |
|---|------------------|---|------------------------|
| A | Driving chain | B | Clamping bar |
| C | Driving chain | D | Self-aligning bearings |
| E | Locked cylinders | F | Cylinder arm |
| G | Sprocket | H | Drawing bar |
| I | Square bar | J | Blanket under test |

Figure BB.1 – Equipment for the mechanical strength test of blankets

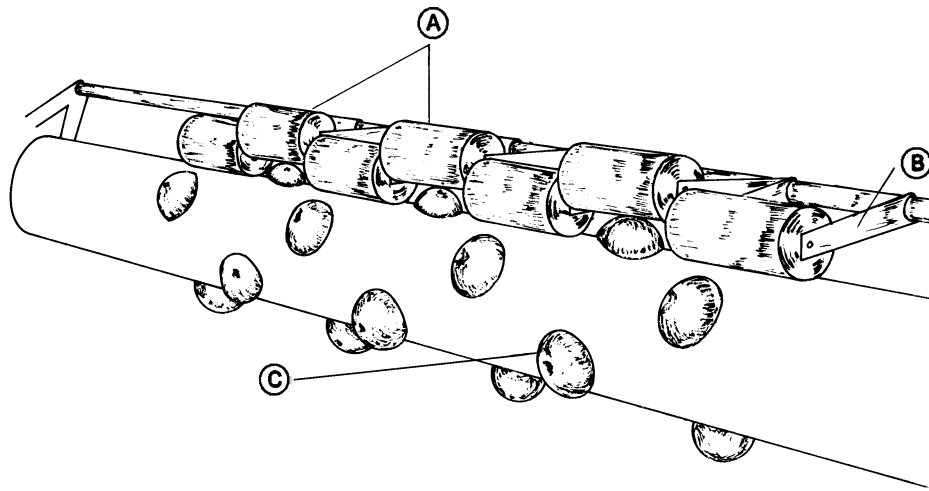

IEC 2222/02

Key

A Cylinder

B Cylinder arm

C Solid rubber spheres

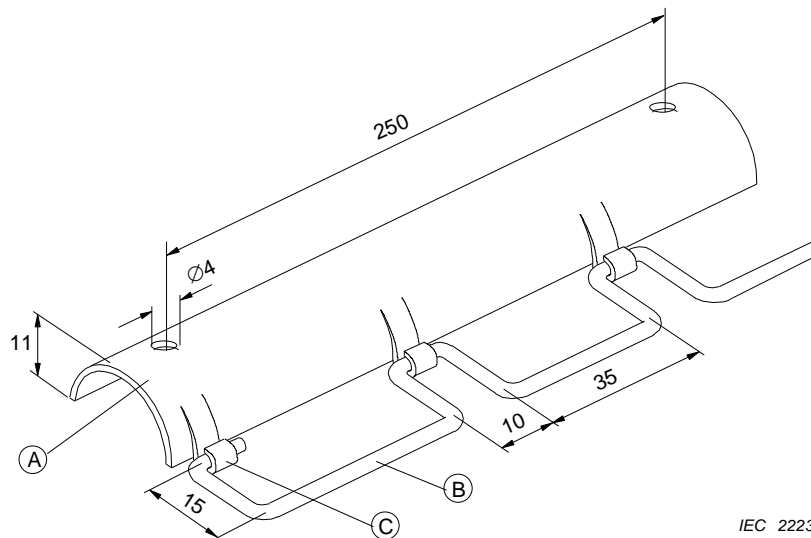
Figure BB.2 – Detail of the drum and cylinders

IEC 2223/02

*Dimensions in millimetres***Key**

A Steel channel 25 mm diameter, 1,6 mm thick

B Steel wire swivel, 2,5 mm diameter

C Hinges brazed to channel

Figure BB.3 – Detail of the clamping bar

Annex CC

(normative)

Clothing

The following modifications to this standard are applicable for clothing.

NOTE Additional subclauses and notes in this annex are numbered starting with 201.

3 Definitions

3.1.9 Add the following:

Clothing is placed between sheets of thermal insulation. The bottom sheet has a thickness of 2 d and the top sheet a thickness of 0,2 d, as specified in Annex AA. The clothing is positioned so that different **heated areas** are separated from each other unless they are likely to come into contact with each other in normal use.

NOTE 201 It may be necessary to cut the clothing in order to separate the different **heated areas**.

5 General conditions for the tests

5.7 The modification is not applicable.

6 Classification

6.1 Modification:

Clothing shall be **class III**.

7 Marking and instructions

7.1 The marking “Do not use folded or rucked” or the symbol of Figure 101 is not required.

7.12 The instruction “Do not crease the appliance by placing items on top of it during storage” is also applicable to clothing.

Add the following:

The instructions for clothing shall state that if the clothing is likely to be used for an extended period, the control should be adjusted to the setting recommended for continuous use. Instructions shall also include advice on precautions and how to recognize heat fatigue and the onset of heat stroke.

The instructions for clothing, other than **controlled clothing**, shall state the substance of the following:

WARNING: In order to avoid the possibility of heatstroke, disconnect the clothing when moving to an environment having significantly higher temperature.

11 Heating

11.3 Replace the first paragraph of the addition by the following:

Thermocouples used for determining the temperature of **heating elements** are tied to them with textile thread over a length of at least 10 mm. The temperature of the surface of the **flexible part** closest to the human body is determined by means of a thermocouple attached to the centre of a disk of copper or brass 15 mm in diameter and 1,0 mm thick.

11.8 Add the following to Table 101:

Surface of clothing	50
---------------------	----

Add the following to Table 102:

Surface of clothing for use in sub-zero temperatures ^b	45
Surface of other clothing	30

^b Examples of such clothing are garments used in cold stores and in the polar regions.

19 Abnormal operation

19.1 Add the following:

Clothing is subjected to the tests of 19.107, 19.108, 19.201 and 19.202.

19.11.3 Add the following:

The test of 19.203 is not repeated.

19.107 Modification:

The reference to “19.101 to 19.106” is replaced by “19.201 and 19.202”.

19.201 Clothing is operated under **normal operation**, except that the **flexible part** is uncovered and folded in the most unfavourable way so that four layers of the **flexible part** are placed one on top of the other.

NOTE 1 A flattened sleeve is considered to be two layers of the **flexible part**.

A sheet of thermal insulation, having dimensions of 300 mm x 450 mm x 90 mm, is placed on the folded clothing at the most unfavourable location. An evenly distributed mass of 5 kg is placed on the sheet of thermal insulation.

NOTE 2 A sandbag may be used as the mass.

19.202 Clothing is folded so that separate **heated areas** are positioned as close as possible to each other and then placed on the sheet of thermal insulation specified for **normal operation**. The clothing is operated without additional covering.

19.203 Clothing shall be constructed so that failure of a component does not give rise to a temperature that could be hazardous to the human body.

Compliance is checked by carrying out the test of Clause 11 but with controls adjusted to the highest setting recommended for continuous use. Failure of components that could reasonably be expected to occur during normal use is simulated, except that switching contacts are not short circuited. Only one fault condition is applied at a time.

NOTE 1 **Heating elements** and internal wiring are not considered to be components.

NOTE 2 Failure of components that could be expected are the fault conditions specified in a) to g) of 19.11.2.

During the test, the temperature of the surface of **controlled clothing** shall not exceed 75 °C. The temperature rise of the surface of other clothing shall not exceed

- 70 K, if the clothing is intended for use in sub-zero temperatures,
- 55 K, for other clothing.

21 Mechanical strength

21.1 Add the following:

Compliance for clothing is checked by the tests of 21.103 to 21.107.

21.104 Modification:

The plywood support is covered by a sheet of thermal insulation, as specified in Annex AA, having a thickness of 36 mm.

22 Construction

22.105 Not applicable.

25 Supply connection and external flexible cords

25.1 Modification:

Clothing shall be fitted with an appliance inlet.

25.23 The addition is applicable to clothing.

30 Resistance to heat and fire

30.2 Add the following:

Clothing is subjected to the tests of 30.2.2.

Bibliography

The bibliography of Part 1 is applicable except as follows.

Addition:

IEC 60335-2-66, Household and similar electrical appliances – Safety – Part 2-66: Particular requirements for water-bed heaters

IEC 60335-2-71, Household and similar electrical appliances – Safety – Part 2-71: Particular requirements for electrical heating appliances for breeding and rearing animals

IEC 60335-2-81, Household and similar electrical appliances – Safety – Part 2-81: Particular requirements for foot warmers and heating mats

IEC 60601-2-35, Medical electrical equipment – Part 2: Particular requirements for the safety of blankets, pads and mattresses intended for heating in medical use

SAUDI ARABIAN STANDARD	SASO GSO IEC 60335-2-17/2008
-------------------------------	-------------------------------------

Annex AAA

National Modifications for

the Values of the Values

of the Rated Voltages and Frequencies

With respect to the rated voltages and frequencies, the following modifications shall be applied:

Clause No.	Text as specified in IEC 60335-2-17	Text after modification	Remarks
1, First Paragraph	<p>This Clause of Part 1 is replaced by the following:</p> <p>This International Standard deals with the safety of electric blankets, pads clothing and other flexible appliances that heat the bed or human body, for household and similar purposes, their rated voltage being not more than 250 V.</p>	<p>This Clause of Part 1 is replaced by the following:</p> <p>This International Standard deals with the safety of electric blankets, pads clothing and other flexible appliances that heat the bed or human body, for household and similar purposes, their rated voltage and rated frequencies being as specified in</p>	

SAUDI ARABIAN STANDARD	SASO GSO IEC 60335-2-17/2008
-------------------------------	-------------------------------------

	Tables AAA-1 & AAA-2.	
--	-----------------------	--

Table AAA-1

Single-Phase Rated Voltages & Rated Frequencies in the GCC Countries

Country Name	Rated Voltage V	Rated Frequency Hz
United Arab Emarits	240	50
Kingdom of Bahrin	230	50
Kingdom of Saudi Arabia	220	60
Sultanate of Oman	240	50
Qatar	240	50
Kuwait	240	50

Table AAA-2

Three-Phase Rated Voltages & Frequencies in the GCC Countries

Country Name	Rated Voltage	Rated Frequency
---------------------	----------------------	------------------------

SAUDI ARABIAN STANDARD	SASO GSO IEC 60335-2-17/2008
-------------------------------	-------------------------------------

	V	Hz
United Arab Emarits	-	-
Kingdom of Bahrin	-	-
Kingdom of Saudi Arabia	380	60
Sultanate of Oman	-	-
Qatar	-	-
Kuwait	-	-

DRAFT STANDARD

N0. 15782

**HOUSEHOLD AND SIMILAR ELECTRICAL APPLIANCES –
SAFETY –**

**PART 2-17: PARTICULAR REQUIREMENTS FOR
BLANKETS, PADS, CLOTHING AND SIMILAR FLEXIBLE
HEATING APPLIANCES**

The preliminary draft of this Standard has been prepared by the work team composed of the following:

Name	Agency
1. Eng. Youssef Abdel-Hamid obaya	Saudi Specialized Laboratories Co. (Motabaqah)
2. Eng. Hussien Saad Hammam	Al-Babtain Co.

The draft Standard was accepted for distribution to the concerned bodies in meeting No. (...) of the Technical Committee No. (1) "Household Appliances and Their Accessories" composed of the following:

Name	Agency
1. Dr Mohammed A. Al-Kadi	King Saud University, Faculty of Engineering
2. Eng. Youssef Abdel-Hamid obaya	Saudi Specialized Laboratories Company (Motabaqah)
3. Eng. Saleh Al-Ghamdy	The technical Faculty – Riyadh
4. Eng. Cherine Helmy Gohary	General Electric Internationa
5. Eng. Abdullah Al-Ghamdy	Riyadh Municipality
6. Eng. Amro M. Mohammed	SASO